

Green Infrastructure Project Guide for Fairbanks, Alaska

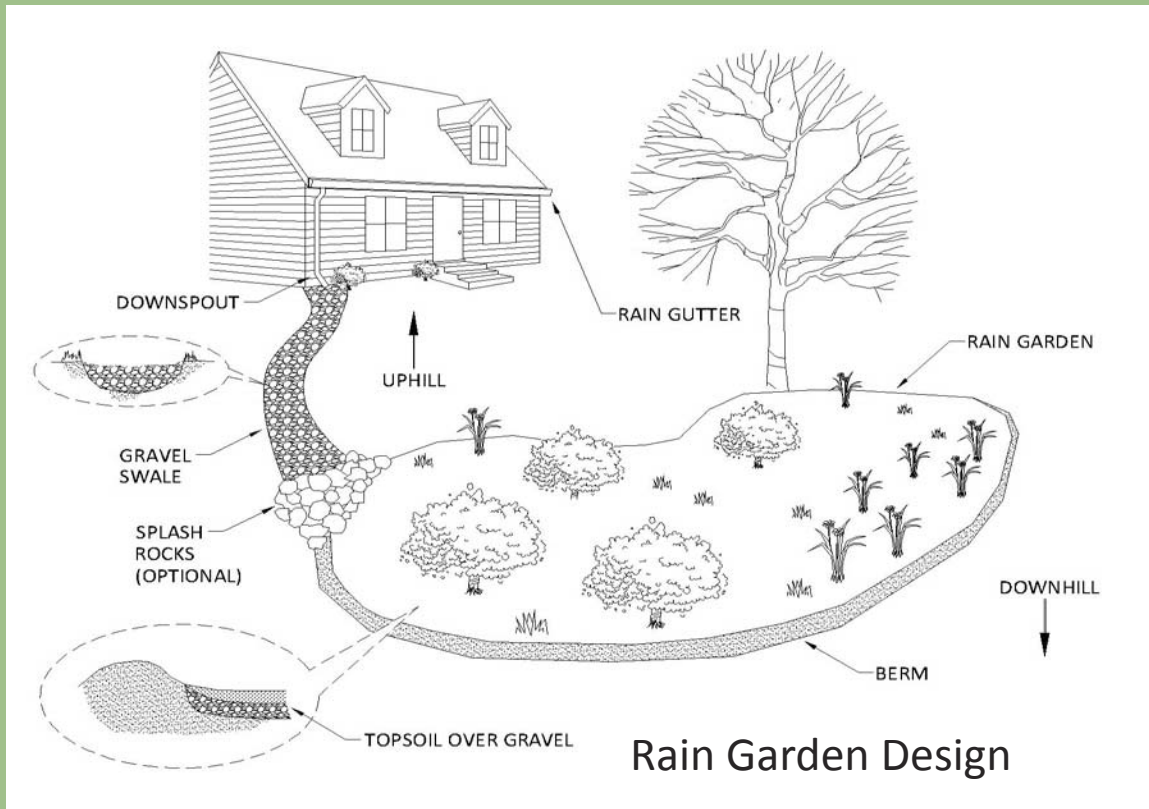

Green Infrastructure Project Guide for Fairbanks, Alaska

By

Sarah Heinchon, Cold Climate Housing Research Center
Melissa Sikes, Fairbanks Soil and Water Conservation District
Jeff Murray, GW Scientific

January 2015
3rd Edition



www.fairbanksgig.com

Suggested Citation:

Heinchon, S., Sikes, M., & Murray, J. (3rd ed. 2015). Green Infrastructure Project Guide for Interior Alaska. Fairbanks, AK: City of Fairbanks.

Acknowledgements

Development of this guide was made possible by:

American Recovery & Reinvestment Act Funds
Granted By the Alaska Department of Natural Resources Division of Forestry

and

Fairbanks Soil and Water Conservation District
Funds granted through the Natural Resource Conservation Service
and the US Fish and Wildlife Service

We would also like to thank:

Jackson Fox, City of Fairbanks
Dean Hughes, Alaska Department of Fish and Game
Amber Bethe, Alaska Department of Fish and Game
Michael Lilly, GW Scientific
Mitch Osborne, US Fish and Wildlife Service
Joni Scharfenberg, Fairbanks Soil and Water Conservation District
Jewelz Barker, Tanana Valley Watershed Association
Patricia Joyner, Alaska Department of Natural Resources
Cindy Guildler, Alaska Department of Environmental Conservation
Chandra McGee, Alaska Department of Environmental Conservation
Michele Hébert and the University of Alaska Fairbanks Cooperative Extension Service
Lowe's Home Improvement in Fairbanks, Alaska
Tanana Valley Farmers Market

DISCLAIMER

Reference to any specific commercial products, process, service, manufacturer, company, or trademark does not constitute its endorsement or recommendation by any agency, business, or other sponsor or contributor to this guide.

F Table of Contents

- Introduction** 1
 - What is Green Infrastructure? 1

- Green Infrastructure Group** 2
 - Who We Are. 2
 - What We Do 2
 - GIG Website 2
 - Where Can I Get Help? 2

- Selection and Adaptation of Green Infrastructure Projects** 3
 - Feasibility. 3
 - Cost-effectiveness 3
 - Ease of Installation 3
 - Level of Maintenance. 3

- Fairbanks Area Climate and Geology** 4
 - Geology 4
 - Climate. 4
 - Precipitation 4
 - Water Quality 4

- Fairbanks Area Green Infrastructure Project Examples** 5

- Green Infrastructure Comparison Table** 7

- Selected Green Infrastructure Projects** 8
 - Dry Wells 9
 - Flow-Through and Infiltration Planters 13
 - Grass Reinforcement Mesh 17
 - Green Roofs. 21
 - Permeable Pavers 25
 - Rain Barrels 29
 - Rain Gardens 33
 - Riparian Zone Revegetation. 37
 - Stormwater Trees 41
 - Swales and Berms 45

- Bibliography** 49

Introduction

What is Green Infrastructure?

Green Infrastructure (GI) projects are environmentally friendly and cost effective methods for managing stormwater runoff. GI mimics nature to reduce and treat stormwater at its source. It allows rain and snow melt to soak slowly into the soil or to be used by plants and people rather than running off. GI is often less expensive than “grey infrastructure”, which includes storm drains and pipes that move water away from a site. It is also less harmful to the environment because it does not allow runoff to carry pollutants from yards, parking lots, and roads to streams, rivers and lakes.

Green infrastructure may be small in scale like rain gardens, rain barrels and cisterns, flow-through or infiltration planters, and permeable pavers. It may be at a landscape scale like forests, parks and buffers of trees and other plants along streams and river banks.

The many benefits of GI include improved water and air quality, ecological benefits to fish and wildlife and better quality of life for residents. A series of buffers from one neighbor to another can also create natural corridors for fish and other wildlife along rivers and between natural open spaces and parks. These buffers also filter and store runoff from paved areas and protect rivers and lakes from pollutions.

This Green Infrastructure Project Guide is intended to serve as a guide for homeowners and small business owners in the Fairbanks area who want to build GI projects on their properties. It includes design concepts and detailed instructions for GI projects that will work in the Fairbanks area.



Rain Garden

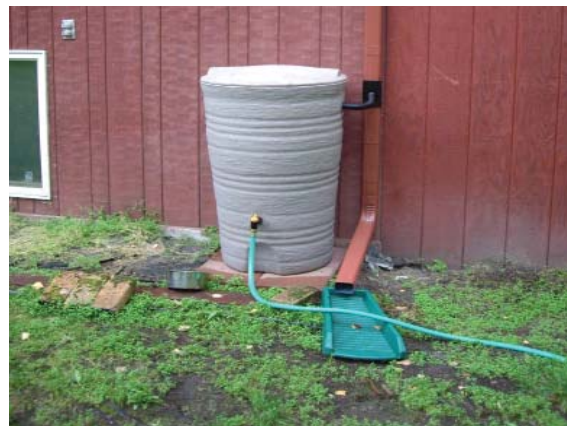

Rain Barrel



Streambank Restoration



Dry Well

Green Infrastructure Group

Who We Are: The Green Infrastructure Group (GIG) is a diverse group of partners that share a common goal of a healthy watershed. The GIG supports many small scale green infrastructure projects as examples of how small projects are important to bigger planning goals for the community. As a group, the GIG can share costs and resources, and more effectively implement projects.

What We Do: The Green Infrastructure Group (GIG) works to create a cleaner and healthier watershed by making Green Infrastructure a common practice for home and business owners. Through community support and involvement, the GIG promotes sustainable use of our natural environment for the benefit of present and future generations.

GIG Website: This website contains many helpful ideas and information to help you get started with your project. www.fairbanksgig.com

Where can I get help? Listed below are some other websites with helpful information and links to local Fairbanks area agencies that can provide assistance with Green Infrastructure projects:

1. The Environmental Protection Agency:

<http://water.epa.gov/infrastructure/greeninfrastructure/index.cfm>

2. Alaska Department of Environmental Conservation:

<http://dec.alaska.gov/water/wqsar/>

3. Fairbanks Soil and Water Conservation District:

<http://www.fairbankssoilwater.org/resources-green-infrastructure.htm>

4. Cold Climate Housing Research Center:

<http://www.cchrc.org/green-infrastructure>

5. Fairbanks Stormwater Advisory Committee:

<http://co.fairbanks.ak.us/PWorks/StormWaterManagementProgram/howtogetinvolved.htm>



Selection and Adaptation of Green Infrastructure Projects for Fairbanks

This guide is intended for Fairbanks area homeowners and small business owners. Selection of the GI projects was based on several factors:

Feasibility

The climate makes it difficult to collect and use stormwater runoff in Fairbanks due to infrequent heavy rains, a brief growing season, frozen ground and areas of permafrost, however we think all projects in the guide will work in the Fairbanks climate based on experience with each one

Cost-Effectiveness

We looked at the cost of shipping and local availability when selecting GI projects for Fairbanks. Some projects, while practical and inexpensive at the outset, were too expensive when shipping costs were included. Materials for projects selected are available locally for a reasonable cost.

Ease of Installation

This guide focuses on projects that home or small business owners can do themselves, or with help from a contractor. One exception is green roofs, which have been built atop log cabins for many years in Fairbanks. Green roofs should be installed by a professional if at all possible to ensure they are safe and functional and to avoid any insurance problems.

Level of Maintenance

We selected projects with low maintenance levels. GI projects in Fairbanks usually require more maintenance than in less extreme conditions. Home and business owners are less likely to install GI projects that require high maintenance.



Flow Through Planter designed, built and installed by Joseph Rourke, North Pole, Alaska

Fairbanks Area Geology and Climate

Geology

Fairbanks is located in the Tanana River Valley between the White Mountains and the Alaska Range. The valley bottom consists of permeable flood-plain, but the hills are covered in loose sediments and silt that freezes each year. Areas of permafrost are also found on the north facing slopes of hills and in the poorly drained lowlands (Geologic Map of Central (Interior) Alaska Northeastern Region, 1998).

Permafrost reduces the porosity of the soil and makes it harder for water to soak in. Loess, windborne silt-sized sediment, also contributes to poor draining soils, but can be amended to increase infiltration.

The groundwater level in the valley bottom is usually between 5 to 20 feet below the surface, and is seasonally affected. The lowest levels are just before the spring snowmelt, and the highest levels occur after spring snowmelt (USGS, no date).

Climate

Fairbanks is classified as a sub-arctic climate and experiences some of the largest, and most extreme, climatic variations in North America. The temperatures range from bitter cold winters to hot summers that can cause headaches when trying to implement successful GI projects.

Seasons and Precipitation

Fairbanks is typically covered in snow from October to April. Winter and spring seasons are especially dry. In the summer, rainfall peaks in July and August, but the amount varies from year to year.

These GI projects are designed to process snowmelt runoff in the spring and rainwater runoff in the summer. The highest amount of runoff occurs during break-up in the spring when GI projects are less effective because the ground is frozen and water can't soak into the ground. However, water that remains standing will eventually soak into the ground as it thaws.

Water Quality

As Fairbanks has grown, the amount of stormwater has increased because there are more impervious (hard) surfaces so water runs off rather than soaking in. This runoff also carries pollution such as trash, petroleum products, soil, solvents, fertilizer, and pathogens into water bodies, such as the Chena River, and degrades the water quality .

Poor water quality can harm cold water fish species as well as reducing recreational opportunities for residents. GI projects can help reduce stormwater damage and improve water quality by slowing down and cleaning up runoff before it reaches the river.

Fairbanks Area Green Infrastructure Projects

Here is a list of Fairbanks area GI projects you can visit:

Rain Gardens

1. Tanana Valley Farmers Market
2600 College Road, Fairbanks
907-456-3276
Rain Garden was designed by the advanced Conservation Corps students in the summer of 2012. Includes driftwood benches.
2. Catholic Schools of Fairbanks/Immaculate Conception School
615 Monroe Street, Fairbanks
907-456-4574
Designed to keep rainwater from flooding the large veggie and flower garden.
3. Woodriver Elementary School
5000 Palo Verde Avenue, Fairbanks
907-479-4211
Two rain gardens near the front entrance to the school. Designed by students to reduce spring flooding and beautify the school grounds.
4. Carlson Center
2010 2nd Avenue, Fairbanks
Large rain garden to the west side of the parking lot near the river. Designed by Laura Minski and installed by the Tanana Valley Watershed Association and volunteers.



Rain Garden at the Tanana Valley Farmer's Market



Rain Garden/Swale at Immaculate Conception School



Rain Garden at Woodriver Elementary School

Dry Wells

1. Golden Heart Plaza
1st Avenue, Fairbanks
Installed to reduce puddles that are a problem during events in the park.
2. David Hayden, Architect L64 Designs
147 3rd Avenue, Fairbanks
907-474-0064 (must call ahead of visit)
Two dry wells installed to improve drainage near the garage.



Dry Well at the Downtown Golden Heart Plaza

Fairbanks Area Green Infrastructure Projects

Rain Barrels

1. Cold Climate Housing Research Center
1000 Fairbanks Street, Fairbanks
907-457-3454 (ask at front desk for tour)
Rainwater catchment system for watering plants, toilet flushing, and fire sprinkler system.
2. Jo Romine
3980 Dunlap Avenue, Fairbanks
907-474-0044 (can be viewed from street, but call ahead if entering property, she'd love to talk to you)
Two rain barrels with plans to have water directed to a rain garden.



Jo Romine's Rain Barrel System

Flow Through Planter

1. The Big I
122 North Turner Street, Fairbanks
Located near the rear entrance.



Big I Flowthrough Planter

Green Roof

1. Cold Climate Housing Research Center
1000 Fairbanks Street, Fairbanks
907-457-3454
Ask at the desk to see the green roof.
2. Old Steese Post Office Cabins
Swan Lane, Fairbanks
Drive by to look at multiple green roofs, not all in good shape.



Green Roof near Old Steese Post Office

Riparian Zone Restoration

1. Shoreway Park
Doyon Place, Fairbanks
North bank of the Chena River, restored bank.
2. Fairbanks North Star Borough Building
809 Pioneer Road, Fairbanks
Root wad installation to repair streambank and improve wildlife habitat.
3. Carlson Center
2010 2nd Avenue, Fairbanks
Streambank restoration along Chena River near the large rain garden.



FNSB building root wad project during construction

Green Infrastructure Project Comparison Table

After considering all of these factors, the following 10 green infrastructure projects were selected. The cost estimates were based on materials needed, equipment rentals, and shipping costs; and the runoff volume reduction percentages were derived from the "Technical Memorandum: The Runoff Reduction Method" (Hirschman & Collins, 2008)

Green Infrastructure Applications Feasible for Fairbanks					
Project	Cost Estimate	Time Estimate (days)	Ease of Installation	Runoff Volume Reduction (%)	Maintenance Level
Rain Barrel	\$70 - \$200	1	Easy	40	Moderate
Rain Garden	\$10 - \$15 per sq ft	1 - 3	Moderate	40 - 80	Moderate
Stormwater Trees	\$10 - \$100	1	Easy	50 - 90	Low
Infiltration and Flow-Through Planter	\$60 - \$250	1 - 2	Moderate	50 - 90	Moderate
Dry Well	\$10 - \$20	1 - 2	Moderate	50 - 90	Moderate
Swales and Berms	\$3 - \$7 per sq ft	1 - 3	Moderate	40 - 60	Moderate
Green Roof	\$20 per sq ft	5 - 10	Difficult	45 - 60	Low
Permeable Paver	\$10 per sq ft	1 - 2	Moderate	45 - 75	Low
Grass Protection Mesh	\$1.25 per sq ft	1	Easy	10 - 20	Low
Riparian Zone Revegetation	\$300 - \$1000	1 - 4	Moderate	10 - 20	Low

Green Infrastructure Applications Not Feasible for Fairbanks					
Project	Cost Estimate	Time Estimate (days)	Ease of Installation	Runoff Volume Reduction (%)	Maintenance Level
Porous Asphalt	\$8 - \$10 per sq ft	1 - 3	Difficult	45 - 75	High
Xeriscaping	\$10 - \$15 per sq ft	2 - 4	Difficult	10 - 20	Moderate
Retention grading	\$1 per sq ft	3 - 4	Difficult	0 - 15	Low

Selected Green Infrastructure Projects

The following project guides will help you choose projects that are appropriate for your property and lifestyle.

List of Projects

Dry Wells
Flow-Through and Infiltration Planters
Grass Reinforcement Mesh
Green Roofs
Permeable Pavers
Rain Barrels
Rain Gardens
Riparian Zone Revegetation
Stormwater Trees
Swales and Berms

Sections of Each Project Guide

An explanation of the project
Installation difficulty
Cold climate considerations for the project
Materials list
Tools required
Installation steps
A diagram of the project
Expected maintenance
Cost estimate
Time estimate
Pros and cons of the project
A list of sources for more information

Dry Wells

Does Your Yard Flood Frequently?

A dry well is an underground structure that helps runoff soak slowly into the ground.. A dry well is composed of a perforated pipe that directs roof runoff into a garbage can or metal tube with holes that is set in a small pit lined with gravel. This pit helps filter harmful chemicals.

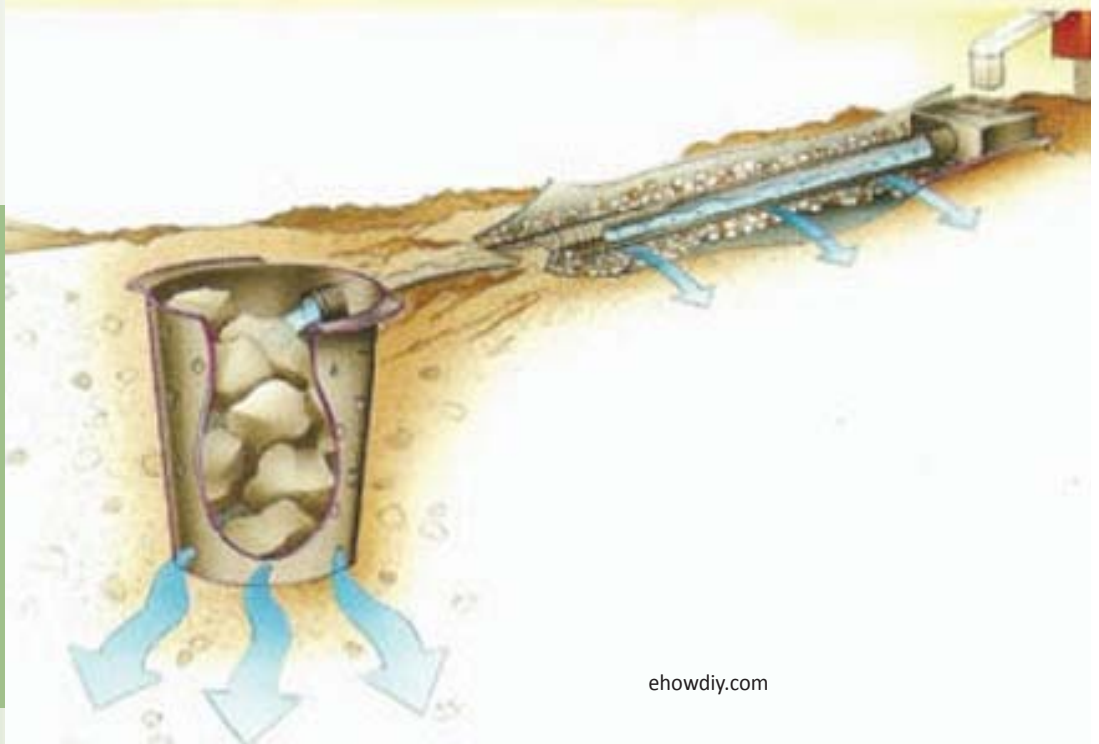

ehowdiy.com



<http://www.tincancabin.com/>

A dry well is a simple way to help excess water soak into the ground. It consists of a buried drain pipe underneath a downspout that carries the water to a holding container made from a plastic trash can or a metal culvert with holes in its sides. The runoff water then percolates into the soil.

Cold Climate Considerations:

The dry well must be disconnected from the downspout in the fall to prevent ice dams from forming in the gutters.

Cost Estimate:

- \$75-150 per well

Time Estimate:

- This project will take one to two days to complete.

Pros:

- Reduces water runoff
- Increases groundwater infiltration
- Requires limited space
- Minimal maintenance required
- Homeowner can install without assistance

Cons:

- Can't process large volumes of water
- Surface freezing reduces the water retention potential
- The perforated pipe can become blocked by ice or soil

Maintenance:

- Disconnect the downspout from the PVC pipe in the fall and reconnect it in the spring.

Materials:

- 4-6" (10.2-15.2cm) diameter section of perforated PVC pipe with a length equal to the distance between your drainage point and the holding container.
- 2 PVC connection rings, same diameter as pipe
- Silicone Caulking
- Grated catch basin (see pic to the right)
- Large covered holding container (garbage can 30+ gallons) with lid.
- Medium sized (1"-2"diameter) gravel or landscape rock enough have 2 inches of rock on the bottom of hole, to fill the inside of holding container, and to line the trench from drainage pipe.
- Geotextile or weed blocking landscape fabric

Tools:

- Shovel
- Hole saw
- Drill with .5 in bit
- Heavy duty Scissors (to cut landscape fabric)
- Tape measure

Grated Catch Basin



PVC Connection Ring



Before starting, test the infiltration rate of your soil:

- Dig an eight by eight inch hole within the designated area after the ground has thawed in the spring.
- Fill the hole with water and check the depth of the water every hour for at least three hours.
- If the water level in the hole goes down at least one inch an hour your soil will be able to drain effectively.
- If it takes longer than eight hours for the hole to completely drain, then you should put a gravel layer under your dry well.
- Most locations in Fairbanks have well draining soils. If you live in the hills surrounding Fairbanks, you may have poorly draining soils.

Steps:

1. Find a suitable area on your property:
 - a. Note the direction of runoff and low spots where water collects. These would be good locations for a dry well as long as they follow the location constraints listed below.
 - b. Location should not be on or near septic tanks or wellheads. It is not advisable to plant a garden on top of the dry well for maintenance reasons.
 - c. Before you dig, be aware of underground service lines or utilities. Call 1-800-478-3121 or go online at www.akonecall.com to have the underground lines marked.
 - d. Be sure to choose a site downhill and at least ten feet away from buildings with basements. Too close and water may seep back and cause damage to the foundation.
 - e. Test the infiltration rate of your soil (see directions on p. 10).
2. Dig a trench (10" wide x 14" deep) at least 10 feet from the area where the water comes off the building to where the holding container will be. Use a shovel to create a slight slope in the trench so the water will flow toward the dry well.
3. Dig a wide area near the downspout and install the grated catch basin under downspout.
4. Dig out the hole for the holding container. The top of the container should be 8 inches below the surface after 2" of gravel is added on the bottom of the pit.
5. Line the trench and pit with landscape fabric.
6. Spread 2" of gravel along the bottom of the trench and pit.
7. Drill 25-30 .5"-1" sized drainage holes along the bottom and halfway up the sides of the holding container.
8. Cut an entry hole in the side of the holding container, approximately 10 inches below the top of the container.
9. Attach the perforated PVC pipe to the container with the PVC connection ring using the caulking to seal it. Allow to dry for 1 hour at least.
10. Install holding container and PVC into the hole and trench.
11. Fill holding container with remaining gravel or larger rocks
12. Attach the PVC pipe the grated catch basin using the second PVC connection ring and seal it. Again let dry.
13. Test the system by pouring water over the top of the grated catch basin.
14. Place the cover on the holding tank. Bury the tank and the pipe with the soil. Tamp down. Sod if desired.



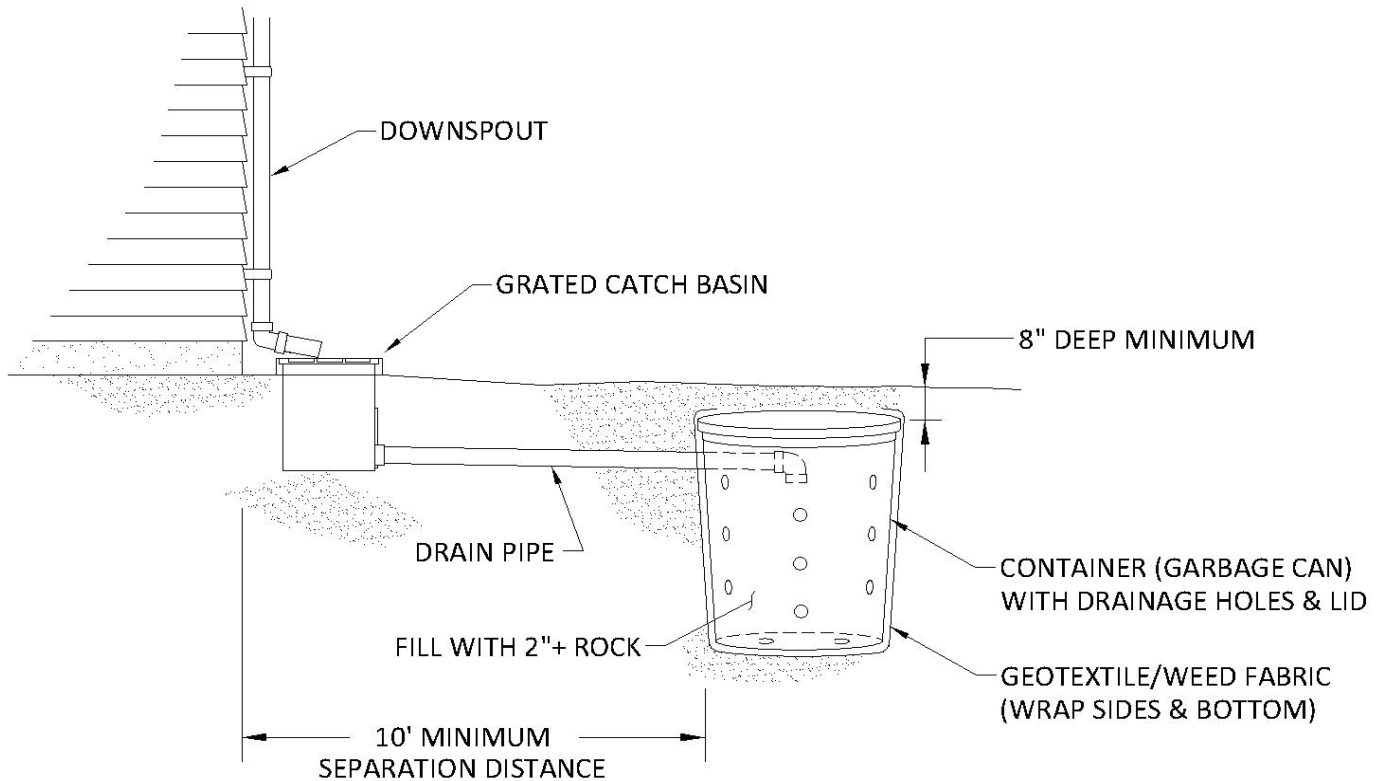

For more information about this and other Green Infrastructure Projects please visit:

www.fairbanksgig.com

Sources:

Pennsylvania Stormwater Management Manual, French Drains

www.bfenvironmental.com/pdfs/Frenchdrains.pdf

Poribesh, Drywell for Stormwater Drainage

www.poribesh.org/Documents/drywell.pdf

Wikihow Dry Well instructions including pictures

www.wikihow.com/Build-a-Dry-Well

Tree People, Install a Drywell

www.treepeople.org/install-drywell

EHow DIY Dry Well Project

ehowdiy.com/basement_drainage_solution_how_to_install_a_dry_well.htm

Flow-Through Planters Infiltration Planters

Want to water less?

A flow-through planter has a closed bottom with a porous pipe that drains the water after it has been filtered by the plants and soil.

An Infiltration planter has an open bottom to allow water to infiltrate the ground below the planter.



East Multnomah, Oregon SWCD

These types of planters require less watering, filter pollutants and may be used where space is limited. Planters or raised beds can be constructed during the winter months and installed after the ground thaws in the spring. Roof runoff may be used to water flowers but it is not safe to use on vegetables. Which planter you choose can depend on your soil and planter location.

Cold Climate Considerations:

The infiltration and flow-through planters must be disconnected from the downspout in the fall to prevent ice dams from forming in the gutters.

Cost Estimate:

- Between \$150 and \$250 depending on size and materials.

Time Estimate:

- This project will take one to two days to complete.

Materials:

- Planter or raised bed
- Gravel
- Sand
- Universal downspout adapter or flexible down spout extension
- Geotextile or Landscaping/Weed Fabric
- Silicon caulking
- PVC pipe to correspond to the length of the planter or raised bed
- Potting soil
- Mulch
- Plants
- 4 Concrete pavers or cinder blocks to raise planter.

Pros:

- Can be placed right next to a building
- Reduces water runoff
- Increases groundwater infiltration
- Requires limited space
- Minimal maintenance required
- Easy to install
- Inexpensive
- Aesthetically pleasing

Cons:

- Surface freezing in the fall reduces the water retention potential
- A limited list of suitable plants. Only use plants that like moist to slightly moist soils. No vegetables. or edible plants.
- The perforated pipe can become blocked by ice or soil
- Needs good soil for proper wicking

Tools:

- Drill
- 1" Hole Saw
- Small drill bit (for holes in pipe)
- Keyhole saw
- Hacksaw (to cut downspout)



Before starting, test the infiltration rate of your soil:

- Dig an eight by eight inch hole within the designated area after the ground has thawed in the spring.
- Fill the hole with water and check the depth of the water every hour for at least three hours.
- If the water level in the hole goes down at least one inch an hour your soil will be able to drain effectively.
- If it takes longer than eight hours for the hole to completely drain, then you should put a gravel layer under your planter.
- Most locations in Fairbanks have well draining soils. If you live in the hills surrounding Fairbanks, you may have poorly draining soils.



Installing a Flow-Through Planter:

1. Find a suitable location on your property:
 - a. Locate a suitable gutter or corner of the building where rainwater or melting snow is directed.
 - b. Only roof runoff should be redirected into a planter.
 - c. Do not locate on or near septic tanks or wellheads.
2. Using a the 1" hole saw, drill a hole 2-4 inches from the bottom in the middle of one of the sides of the planter. This is for the inflow from the downspout to enter. Use the keyhole saw to make the hole large enough for the downspout adapter or flexible down spout extension.
3. Drill another hole about six inches from the bottom in the front of the planter close to the other end of the planter, not the inflow end, with the one-inch drill bit and use the keyhole saw to make the hole large enough for the smaller PVC pipe.
4. Fill the bottom of the planter with about three inches of gravel.
5. With the small drill bit, drill holes about one-half to one inch apart in the larger PVC pipe. Leave about three inches of one end un-perforated.
6. With the 1" hole saw, in the middle of the perforated PVC pipe drill a hole that will be large enough for the downspout adapter or extension.
7. Set up overflow system: Option 1
 - a. Drill a series of holes (about six inches apart) on the long side of the planter opposite of the inflow pipe.
 - b. Place the holes at the top of where the gravel layer will be.
8. Overflow Option 2 (connect to additional planters or pipe to direct overflow water into ground)
 - a. Do not drill holes on the front side of the planter.
 - b. Place and secure an additional pipe on to the other end of the planter from the inflow pipe. This pipe should bend or be a mixture of bending and straight PVC pipe, so that you can direct the overflow pipe into the ground or into an additional planter.
9. Install planter. Be sure to place the planter on top of the pavers or cinder blocks as you install. Adjust so that it is exactly where you want it before filling it with dirt and plants and modifying the downspout.
10. Modify the downspout so that it directs water into the planter
 - a. Use a hacksaw to cut the downspout at the appropriate height.
 - b. Attach the universal downspout adapter or flexible downspout extension, making sure the adapter/extension is long enough to reach the planter.
 - c. Bury the adapter/extension, or lay it on the ground.
 - d. Insert the adapter/extension into the drilled hole on long side of the planter.
 - e. Attach the adapter/extension to the perforated PVC pipe with silicon caulking, then seal the gap between the adapter/extension and the planter hole.
10. Put another two-inch layer of gravel all along the planter.
11. Lay down geotextile or weed fabric to separate the gravel and soil.
12. Fill the planter with soil. The soil should contain a high level of organic matter. Try to not use soil with clay or silt in it. This will ensure that the soil is able to support the wicking function.
13. Plant. Many plants will do well in the moist-to-slightly-moist soil conditions which these planters will provide. Ask your local nursery for advice on plants that will be happy in this kind of setting. Do not use vegetable or edible plants.
14. Add mulch around the plants.

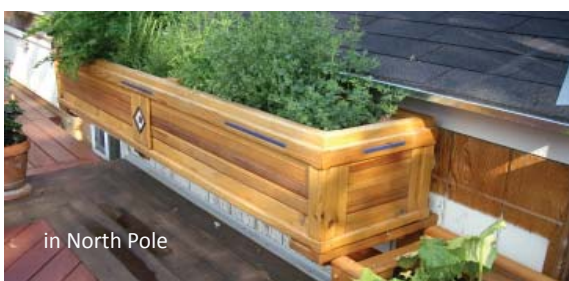

Installing an Infiltration Planter (without a bottom or overflow pipe):

Follow the same directions as the other planter with a few exceptions:

- You will first need to test the infiltration rate of your soil (see pg. 14 for directions).
- There should be no bottom or foam on the bottom of the planter. You may have to cut off the bottom of a planter or drill large holes in the bottom if you buy it pre-made.
- Do not build an infiltration planter on top of permafrost.
- Put a layer of gravel down before installing planter, be sure some gravel is outside the perimeter of the planter.
- Do not install an overflow pipe (directions number 7&8)

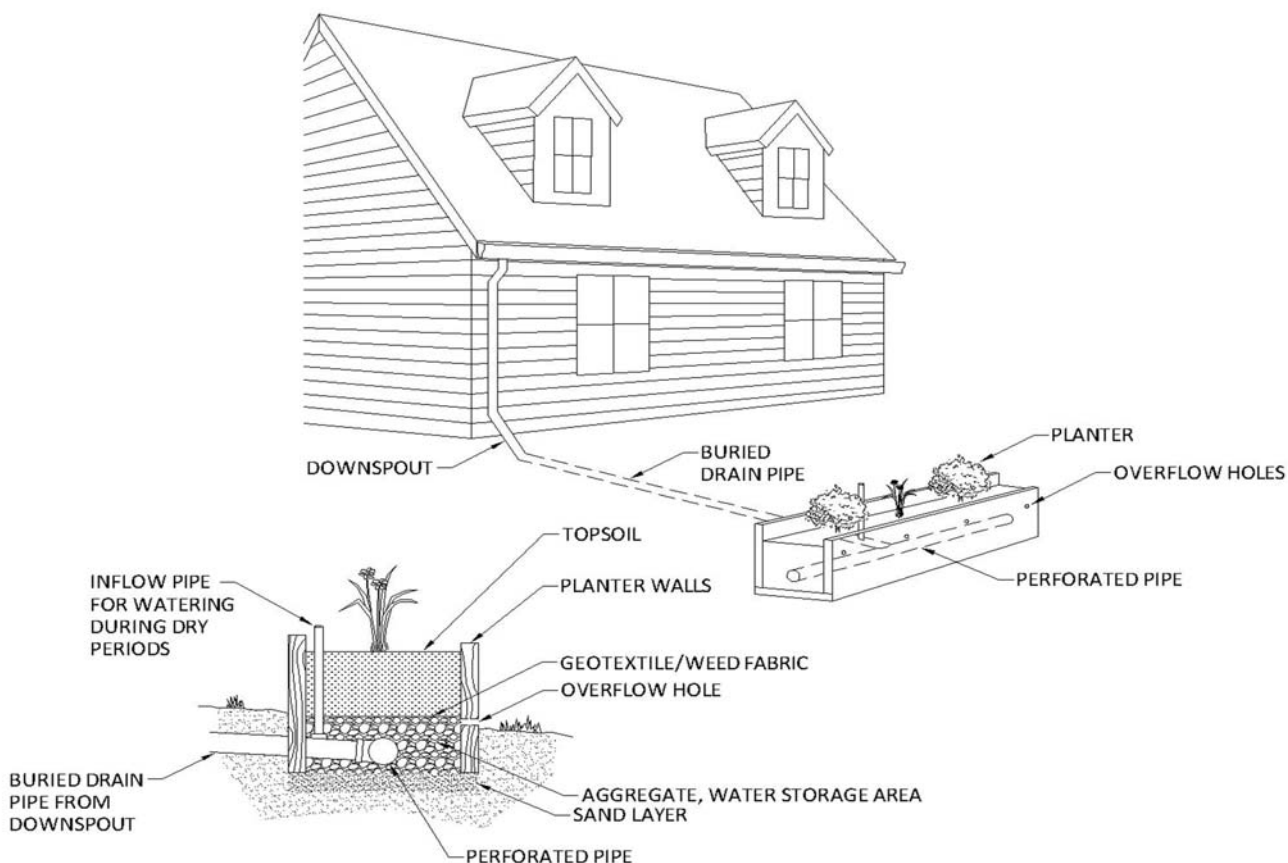

Maintenance:

- Disconnect the downspout from the planter after the first freeze in the fall.
- Weed when and if necessary.
- Clean gutters once a year to help keep debris out of the inflow pipe of the planter.

For more information about this and other Green Infrastructure Projects please visit:

www.fairbanksgig.com

Sources:

Charles River Watershed Association, Low Impact Best Management Practice (BMP) Information Sheet
www.crwa.org/projects/bmpfactsheets/crwa_stormwater_planter.pdf

City of Portland Environmental Services, Flow-Through Planters
www.portlandonline.com/BES/index.cfm?a=127475&c=31870

Hébert, Michele. Building the Ultimate Alaska Raised Box Garden by
www.uaf.edu/ces/michele/articles/general_gardening/raisedBoxGardening.pdf

University of Alaska Fairbanks Cooperative Extension Service, Raised Bed Gardening in Alaska
www.uaf.edu/ces/publications-db/catalog/anr/HGA-00132.pdf

Grass Reinforcement Mesh

Can't stand mud?

A polyethylene grid placed directly on grass and secured with metal U-Pins or plastic pegs helps stabilize the grass so that it can handle more traffic without damage.



Grass reinforcement mesh is a thick plastic mesh that is installed directly onto existing grass to protect, reinforce and stabilize the grass against damage caused by traffic (pedestrians and vehicles.) Grass protection mesh protects grass that is prone to wear, rutting and muddy surfaces. The mesh reinforces the grass for vehicle traffic (car and trucks) or for pedestrian paths and walkways.

Cold Climate Considerations:

Most varieties of this grass mesh can withstand temperatures below -50 F. You may shovel snow off the mesh but do not use a snow plow.

Cost Estimate:

- About \$1.25 per square foot.

Time Estimate:

- The project will take about six hours depending on the size of the area.

Pros:

- Reduces water runoff.
- Increases groundwater infiltration.
- Can be used to control mud problems.
- Aesthetically pleasing.
- Increases property value.
- Homeowner can install without assistance.
- No excavation or soil removal is required.

Cons:

- May not be able to use snow plows over the mesh.
- Have to buy a minimum amount.

Materials:

- Grass reinforcement mesh
- Metal U-Pins
- Grass seed (if starting a new lawn)

Tools:

- Lawn mower
- Hammer
- Seed Spreader



Steps:

1. Mow the grass on an established lawn. For a newly sown area just make sure the soil is well consolidated. The area can be sown before or after the mesh is in place.
2. Unroll the mesh over the selected area and let it stand for at least one hour to help it flatten out.
3. Secure the mesh to the ground with metal U-Pins:
 - a. Secure U-Pins along the middle of the mesh every three to six feet.
 - b. Make sure to secure the perimeter of the mesh every twelve to twenty inches with the metal U-Pins.
 - c. To join two sections of mesh, secure the two ends together with the metal U-Pins every twenty inches along the seam.
4. Do not use the area until the grass has grown through the mesh. This can take up to four weeks.
5. Once the grass is long enough to mow, set the mower blades at a relatively high setting to prevent the blade from cutting the mesh. Once the grass has completely grown around the mesh, the grass can be cut normally.

Maintenance:

- Mow the grass as it grows up around the mesh.
- Monitor integrity of plastic after winter, replace sections if necessary.





Ground leveled, with mesh laid out prior to pinning.

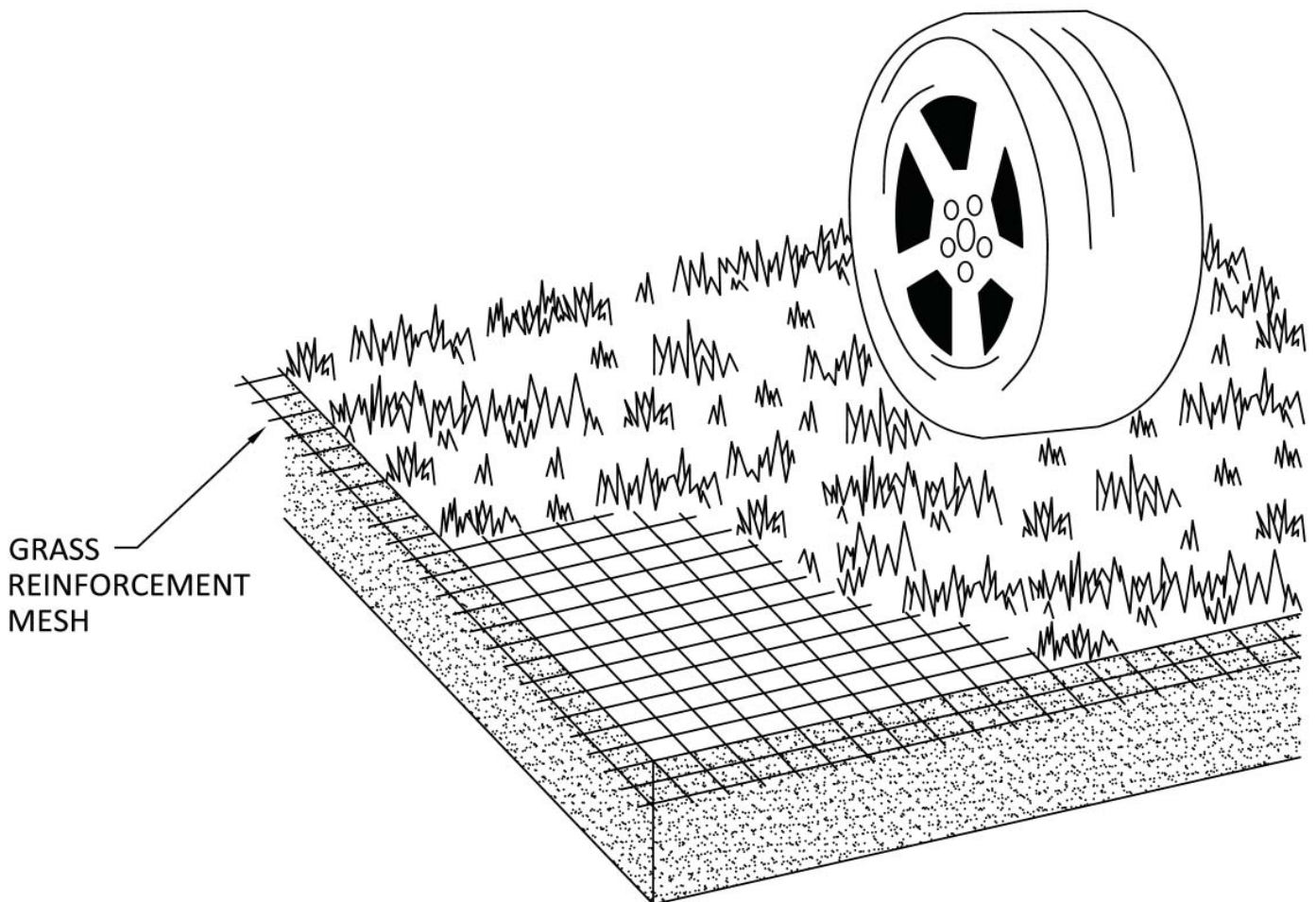



For more information about this and other Green Infrastructure Projects please visit:
www.fairbanksgig.com

Sources:

Boddingtons Ltd, GrassProtecta® Grass Reinforcement Protection Mesh
www.grass-reinforcement.com

Polar Supply 2134 Texaco Street, Unit A Fairbanks, Alaska 99701
907-452-4743 <http://www.polarsupply.com>

Green Roofs

Want lower heating bills?

A green roof is completely or partially covered with vegetation in a growing medium planted over several layers of waterproof membrane, root barrier, and a drainage board. A green roof can absorb up to half of the rainwater and greatly increase the insulation value of your roof.



A green roof, or roof top garden, is a layer of plants growing on a rooftop. Green roofs provide shade and reduce temperatures on the roof surface and in the surrounding air. A green roof can absorb up to half of the rainwater that falls on it and greatly increase the insulation value of your roof. They can be as simple as a 2-inch covering of hardy groundcover or as complex as a fully accessible park complete with trees.

Cold Climate Considerations:

See page 23 for list of specific plants that will survive on a Fairbanks green roof.

Cost Estimate:

- According to Green Roofs for Healthy Cities (see below for reference) green roofs cost \$15 to \$25 per sq ft. The green roof on the CCHRC building cost about \$19 per square foot in 2006. These cost estimates are for professional installation.

Time Estimate:

- This project will take five days to over a week to complete.

Pros:

- Reduces water runoff
- Filters water runoff
- Sound insulation
- Heat insulation
- Aesthetically pleasing
- Increases property value
- Creates habitat for birds and butterflies
- Can have a much longer lifespan than a traditional roofs
- Gardening without having to worry about moose etc.

Cons:

- High initial cost
- Possible insurance issues if installed incorrectly.
- Extensive green roofs can weigh ten to fifteen pounds per square foot when fully saturated
- Some buildings can't be retrofitted to support the extra weight.
- Homeowner would need assistance to construct.

Steps:

The following steps outline the basic elements of a modern green roof. Every green roof installation is unique depending on the building on which it is to be used. It is essential that you consult a professional for more detailed and site specific information before building or adding a green roof.

1. Consult an engineer to determine the proper structural adjustments needed for the building to safely support the substantial extra weight of a green roof. Do not begin installing a green roof until an expert determines that it will support the extra weight. To ensure the green roof is installed properly, hire a roofing company that is familiar with installing these systems. Attempting to install a green roof yourself may negatively impact your homeowner's insurance policy.

Here are the steps the installer will take to install a green roof:

2. Install a vapor control barrier on top of your roof structure.
3. Install the insulation.
4. Install a waterproof membrane such as 60 mil EPDM rubber membrane. This can also act as the root barrier.
5. Install a drainage layer such as a drain board.
6. Install a moisture retention mat on top of the drain board. This helps plant growth by retaining water and making it easily available for plant use.
7. Lay down the growing medium. There are several options of growing medium: inorganic and organic, as well as engineered soils.
8. Plant selected plants.
9. Water the plants until they are established and during dry periods if so desired.

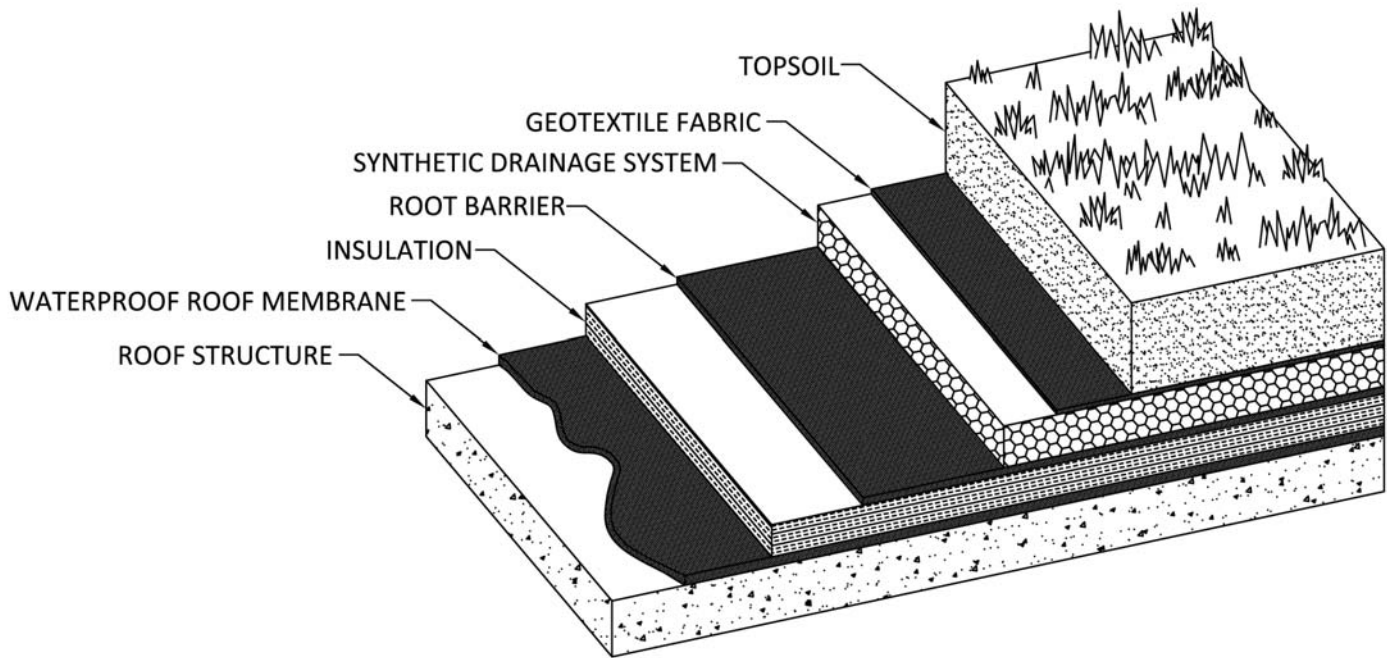

Below is the list of plants that were planted on the south green roof of the Cold Climate Housing Research Center in 2007. They have since naturalized, so not all species are currently represented in the bed. Take into account the amount of sun your roof gets when selecting plants for your green roof.

Plant Name	Latin Name
Nortran Tufted Hairgrass	<i>Deschampsia cespitosa</i>
Alyeska Polargrass	<i>Arctagrostis latifolia</i>
Tilesius' Wormwood	<i>Artemisia tilesii</i>
Tundra Bluegrass	<i>Poa glauca</i> cv. <i>Tundra</i>
Arctared Fescue	<i>Festuca rubra</i>
Mayweed	<i>Tripleurospermum</i>
Tall Jacob's Ladder	<i>Polemonium acutiflorum</i>
Arctic Goldenrod	<i>Solidago multiradiata</i> var. <i>arctica</i>
Nootka Lupine	<i>Lupinus nootkatensis</i>
Alpine Sweetvetch	<i>Hedysarum alpinum</i>
Wainwright Wheatgrass	<i>Elymus trachycaulus</i>
Sourdough Bluejoint Reedgrass	<i>Calamagrostis canadensis</i>

For more information about this and other Green Infrastructure Projects please visit:
www.fairbanksgig.com

Sources:

Cold Climate Housing Research Center, Green Roof website
<http://cchrc.org/green-roof>

Green Roofs for Healthy Cities website
<http://greenroofs.org>

Green Roof Plants: A Resource and Planting Guide, by Edmund C. Snodgrass and Lucie L. Snodgrass, 2006
from Timber Press, Portland, OR.

Living Roofs website
<http://livingroofs.org>

Low Impact Development Center, Inc., Green Roof
www.lid-stormwater.net/greenroofs_home.htm



<http://assets.inhabitat.com/>

Permeable Pavers

Driveway Causing Runoff Erosion?

Driveways often cause problems with runoff. Permeable pavers are concrete blocks or pavers set in gravel to allow water to pass around them and into the soil. Permeable pavers can be used instead of solid concrete or asphalt for driveways, patios, and walkways.



Whenever the ground is covered with non-permeable surfaces such as solid concrete or asphalt, rain can't seep into the soil. As water flows off asphalt or concrete, it can cause erosion or carry pollution into stormdrains and on to rivers and streams. Permeable paving is a system that allows water to pass around the paver and infiltrate in-between the pavers

Cold Climate Considerations:

We do not recommend porous composite pavers. Porous pavers will not last very long in our environment due to the effects of freeze thaw cycles, but they can work but are a more expensive option and difficult to obtain.

Cost Estimate:

- about \$10 per square foot

Pros:

- Reduces water runoff.
- Increases groundwater infiltration.

Cons:

- Using sand or gravel for traction on or near the pavers can reduce the permeability of the pavers.

Time Estimate:

- one to four days depending on the size of the area

Materials:

- Coarse gravel
- Geotextile or landscaping weed fabric
- Bedding sand and / -or pea gravel
- Paving blocks or bricks
- Edge restraints
- Water

Tools:

- Hand tamp or mechanical compactor
- Shovel
- Excavator (optional)
- Hose
- Push broom
- Level

Steps:

1. Evaluate your chosen area of installation with the following guidelines:
 - a. Do not place pavers on permafrost.
 - b. Only roof runoff should be redirected onto permeable pavers.
 - c. Location should not be on or near septic tanks or wellheads.
 - d. Before you dig, be aware of underground service lines or utilities. Call 1-800-478-3121 or go online at www.akonecall.com to have the underground lines marked.
2. Prepare area. If there is an existing surface already remove pavement, pavers, or turf and excavate down one foot deep.
3. Compact the soil with either a hand tamp or a mechanical compactor. Using a hand tamp is not recommended for large areas.
4. Deposit a six inch (minimum) layer of gravel or sand as a base.
5. Lay down a layer of geotextile fabric to keep the sand in place and to prevent weeds from growing.
6. Deposit a one inch layer of bedding sand on top of fabric.
7. Install the edge restraints. Place the restraints along the perimeter of the project. These can be plastic, aluminum, or steel and are available at most hardware stores.
8. Install the permeable pavers with design of your choice.
9. Fill the joints by sweeping coarse sand or pea gravel over the pavers. Or plant moss or grass between the pavers.
10. Compact the pavers with a hand tamp for small areas and a mechanical compactor for large areas.
11. Spray the paved area with water to help compact the sand.

Maintenance:

- Over several years some of the joint sand may erode away. If it does, just spread more joint sand over the pavers and sweep it in.
- Weeding may be necessary throughout the summer to prevent weeds from growing in the cracks between the pavers.
- If the pavers become uneven you can remove the pavers in the affected area, re-level the aggregate base (you may need to add more sand) and reinstall the pavers.
- Sweep the pavers at least every spring to remove dirt and sand, which will prevent the loss of porosity of the pavers.

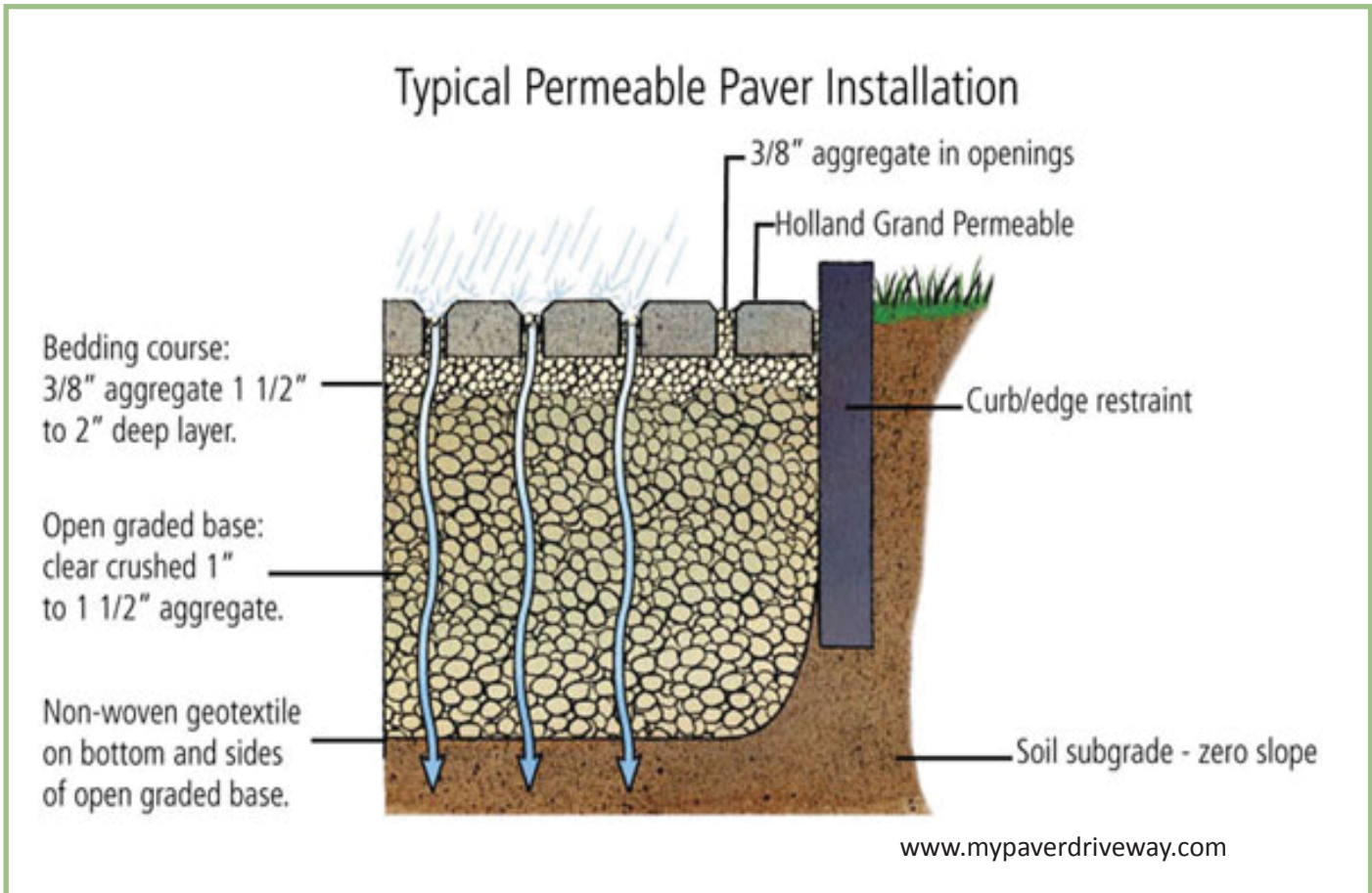

For more information about this and other Green Infrastructure Projects please visit:
www.fairbanksgig.com

Sources:

Interlocking Concrete Pavement Institute

<http://www.icpi.org/>

Low Impact Development Center, Inc., Permeable Pavers

http://www.lid-stormwater.net/permpavers_benefits.htm

Natural Resources Defense Council

<http://www.nrdc.org/thisgreenlife/1106.asp>



Rain Barrels

Need free water?

A rain barrel is used to collect rain water. A simple rain barrel is easy to make using inexpensive materials found at most hardware stores. A rain barrel is an easy way to help the environment and save you money.



About 30,000 gallons of rainfall runs off the average home's roof every year. Using rain barrels to temporarily store and reuse rainwater can conserve drinking water by providing an alternative water source for gardens. Rain barrels can also reduce both the water use charge and sewer charge on your city utility bill. Rain runoff from your roof may flow into a stormdrain. Collecting this water can protect the quality of our streams and groundwater.

Caution: Water collected in rain barrels is coming off a roof, into gutters and downspouts. **IT IS NOT SAFE TO DRINK.** Rain barrel water is fine if used to water non-edible plants such as flowers or lawns. It should not be used to water vegetables. Even water from a metal or plastic roof can contain bacteria from birds or other animals.

Cold Climate Considerations:

The rain barrel must be disconnected from the downspout in the fall to prevent ice dams from forming in the gutters. If you have concerns about mosquito breeding in your rain barrel, be sure that your screen is small enough to not allow adult mosquitoes into the barrel. If this is not possible, add some kitchen oil to coat the surface of the water which will prevent egg deposition and/or larval development.

Other Considerations:

Install your rain barrel where you will use the water in your yard. Locate the rain barrel at the base of a downspout draining from your roof gutter. All rainwater collection systems should have an overflow to a safe disposal location. Even if you have multiple rain barrels, you should have an overflow system.

Cost Estimate:

- Pre-made: \$80 - \$200
- Homemade: \$70 - \$200

Time Estimate:

- The project will take about one to two days.

Pros:

- Reduces water runoff
- Increases groundwater infiltration
- Minimal maintenance required
- Requires limited space
- Collects rainwater for gray water uses

Cons:

- Freezing water can block the pipe and deform the barrel.

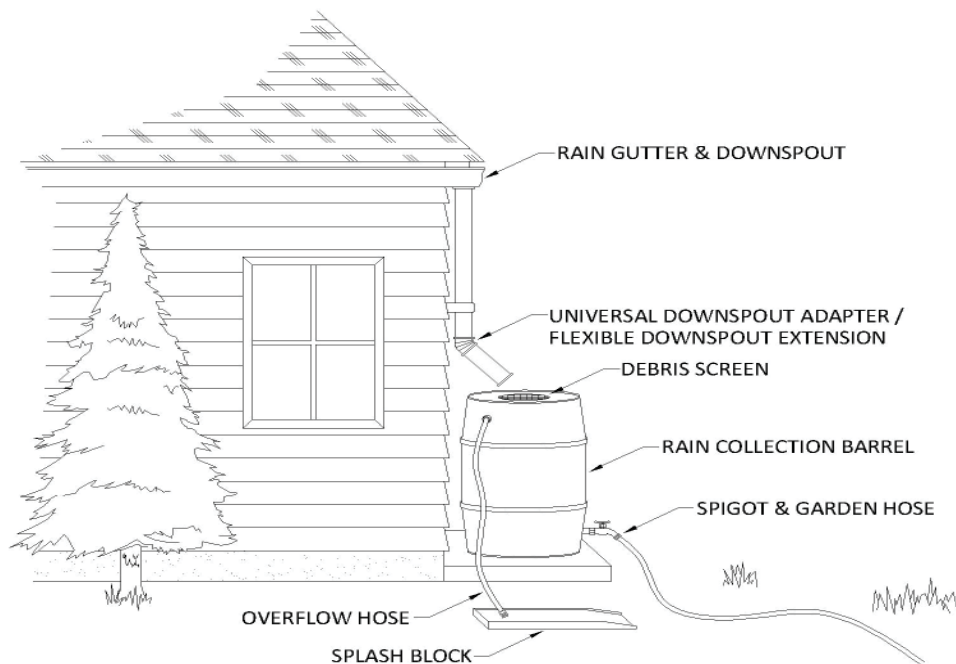

Constructing Your Own Rain Barrel

Materials:

- New 30+ gallon plastic garbage can with lid
- Hose spigot with $\frac{3}{4}$ inch threaded inlet and $\frac{3}{4}$ inch male hose end
- Two $\frac{3}{4}$ inch galvanized locknuts to secure hose spigot from the inside of the barrel
- Four 1 inch (opening) metal washers to provide rigid surface to fasten hose spigot
- Four 1 inch (opening) metal washers to provide rigid surface to fasten hose spigot
- $\frac{3}{4}$ " garden hose or tubing, 4-5 feet long (for overflow hose)
- Silicone adhesive or outdoor caulking
- Teflon tape
- Two $\frac{3}{4}$ " bulkhead fittings with gaskets
- $\frac{1}{4}$ " #6 sheet metal screws (for downspout)
- 2 8x8x12" Concrete or wooden blocks
- Wire screen mesh (enough to cover barrel opening)
- Universal downspout adapter or flexible downspout extension or gutter elbow
- Garden hose (length as desired)
- Splash Block
- 24" Bungie Cord (to secure lid)
- Heat Tape (optional)

Tools:

- Drill
- 1" hole saw
- Small drill bit
- Heavy duty scissors or tin snips
- Utility Knife
- Hacksaw, to redirect gutter to rain barrel
- Tape measure
- Screwdriver or nutdriver
- Adjustable wrench
- Channel lock pliers or crimpers
- Caulk Gun (if using caulk)



Hose Spigots



Bulkhead Fitting with Gasket



1" Metal Washer



1" Hole Saw



Downspout Adapters



Steps:

1. You can calculate the amount of water you can expect to collect using the size of your roof and the average rainfall for Fairbanks. Fairbanks averages about 1.3 inches of rain each month from May to September. This will help you determine how many barrels you will want to install. A rain barrel calculator is available at:
<http://www.rainbarrelguide.com/how-much-water-can-you-collect-in-rain-barrels-during-a-rainfall/>.
2. Level the soil at your site and use the concrete blocks to create a stable platform for the rain barrel.
3. Make an opening at least twice the size of your downspout in the top of the barrel for the incoming water.
4. Attach the wire screen mesh to the hole on top of the barrel to keep debris out.
5. With the 1" Hole Saw, drill a one-inch hole within four inches of the bottom of the barrel.
6. Attach the bulkhead fitting:
 - a. Separate the two parts of the bulkhead fitting, leaving the gasket on the body and put the locknut part aside.
 - b. Wrap Teflon tape around the threads of the bulkhead fitting, smooth into the threads.
 - c. Insert the body through the hole in the tank from the inside, trapping the gasket between the tank wall and the bulkhead fitting.
 - d. From the outside of the barrel, screw the locknut back onto the body over the Teflon tape.

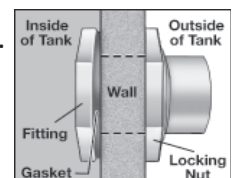

Steps Continued:

7. Attach the hose spigot to the bulkhead fitting.
8. Modify the downspout so that it directs water into the barrel:
 - a. Measure how tall your rain barrel is going to be including the height of the platform and up to five extra inches
 - b. Use a hacksaw to cut the downspout at the appropriate height.
 - c. Attach the universal downspout adapter or flexible down spout extension using the small sheet metal screws
 - d. Place the rain barrel under the downspout so the water will flow into it.
9. Install waterproof heat tape in downspout and barrel (optional but recommended to keep ice dams from forming).
10. Set up the overflow system:
 - a. Drill a hole within three inches of the top of the barrel.
 - b. Insert the plastic hose/tubing into the hole and glue into place with rubber cement or caulking.
 - c. Direct the overflow hose to the splash block, or to a suitable runoff area, or to another rainbarrel.

Maintenance:

- Wash out rain barrel and check washers for integrity every spring.
- Clean off the wire screen periodically throughout the growing season.
- Clean gutters once a year to keep them clear.
- Empty the barrel and reposition the downspout before the first freeze in the fall.
- Clean algae buildup yearly.

For more information about this and other Green Infrastructure Projects please visit:

www.fairbanksgig.com

Sources:

Aquabarrel Kits

www.aquabarrel.com

City of Portland, Oregon, Rain Barrel Plans

www.portlandonline.com/bes/index.cfm?a=182095&c=50367

Healthy Landscapes

www.uri.edu/ce/healthylandscapes/rainbsources.html

Rain Barrel Guide is a website with many articles on rainwater harvesting.

www.rainbarrelguide.com

Rain Garden Networks

www.raingardennetwork.com/rainbarrels.htm

Whatcom County, Bellingham, Washington, Rain Barrel Factsheet

<http://whatcom.wsu.edu/ag/compost/rainbarrel.htm>

Rain Gardens

Want to mow less?

A rain garden is a low area with plants that tolerate and absorb rainwater and filter out harmful chemicals. It is an effective and attractive way to divert runoff from your home's rain gutters.



anchorageaingardens.com

Rain gardens are landscaped areas planted with vegetation that help filter rainwater that runs off roofs, driveways, sidewalks, and lawns. After a storm, the rain garden fills with this water and allows it to naturally filter into the ground rather than running off into the street or a storm drain system.

Cold Climate Considerations:

Due to our varying climactic conditions, it is best to choose plants that are native to Alaska. See the plant list for suggestions.

Cost Estimate:

- Self installed \$3 - \$7 per sq ft
- Professionally installed \$10 - \$15 per sq ft

Time Estimate:

- This project will take one to three days to complete.

Pros:

- Aesthetically pleasing
- Reduces water runoff
- Increases groundwater infiltration
- Increase property value
- Creates habitat

Cons:

- Surface freezing in the fall reduces the water retention potential.
- A limited list of suitable plants

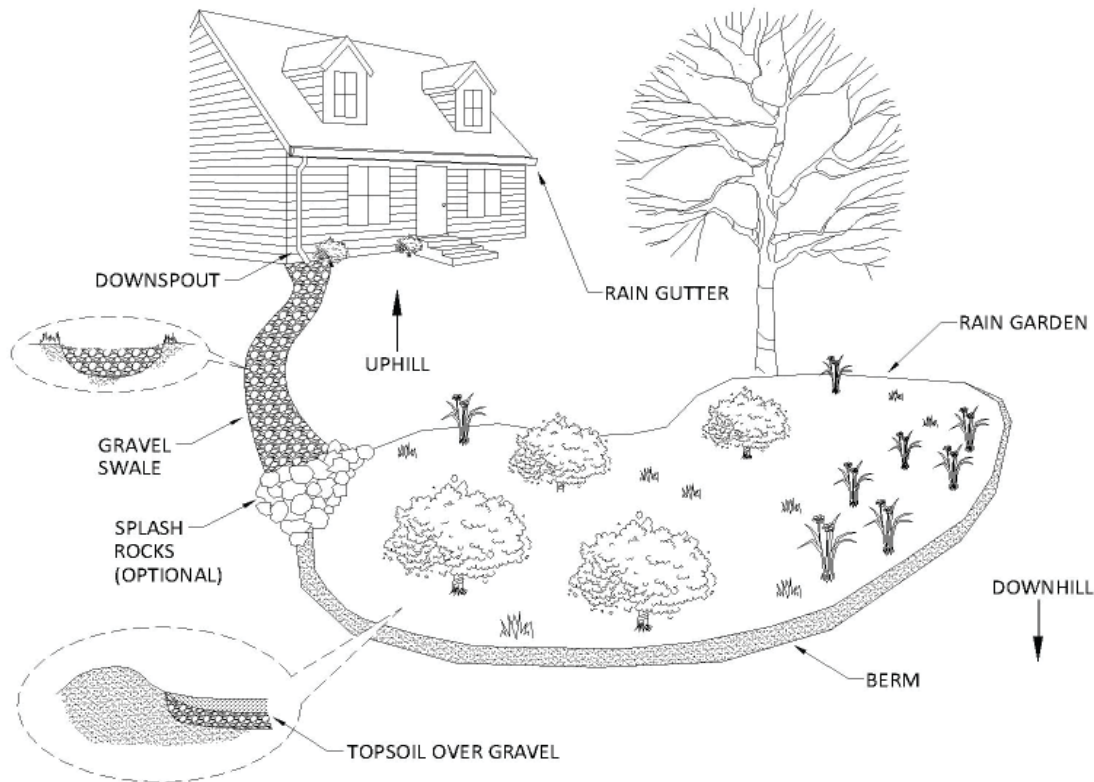

Materials:

- Rain Garden soil mix (if replacing existing soil) 50-60% sand, 20-30% topsoil, 20-30% compost. Amount will vary depending on size of garden.
- Fertilizer mix (10-20-10 in the spring)
- Sand (optional) amount varies depending on garden size. (see step 4)
- Gravel (optional) amount varies depending on garden size. (see step 4)
- Appropriate plants - see list
- Weed-Free Mulch
- Universal Downspout Adapter

Tools:

- Large Roll-out Measuring Tape
- Marking Flags
- Shovel
- Tarp
- Digging fork or Rototiller
- Spade
- Bow rake

Steps:

1. Choose an appropriate size for your rain garden. The more runoff you can redirect to your rain garden, the larger it can be. If you make the garden larger than can be supported by runoff, you will have to water it more during dry periods. If it is too small, water might overflow and plants could be damaged. See www.anchorageraingardens.com/RGmanualWEB.pdf for examples of how to calculate the appropriate size.
 2. Choose the right location for your rain garden:
 - a. Do not build a rain garden in permafrost.
 - b. Note the direction of rainwater runoff and low spots where water collects.
 - c. Make sure that the chosen location is downhill and at least 10 feet away from buildings with basements.
 - d. Location should not be on or near septic tanks or wellheads.
 - e. Before you dig, be aware of underground service lines or utilities. Call 1-800-478-3121 or go online at www.akonecall.com to have the underground lines marked.
 3. Once you have chosen a location, define the borders using marking flags.
 4. Test the infiltration rate of your soil:
 - a. Dig an eight by eight inch hole within the designated area after the ground has had enough time to thaw in the spring.
 - b. Fill the hole with water and check the depth of the water every hour for at least three hours.
 - c. If the water level in the hole goes down at least one inch an hour your soil will be able to drain effectively for a rain garden.
 - d. If it takes longer than eight hours for the hole to completely drain, then you should put gravel layer and then a sand layer under your rain garden.
 5. Remove sod, if needed, and dig a three to four foot deep hole, putting the soil off to the side onto a tarp. Making the rain garden hole this deep and amending the soil will help ensure proper drainage.
 6. Loosen the soil in the hole with a digging fork or a rototiller.
 7. You can place a layer of gravel before replacing the soil. (see step 4) The gravel should be no more than twelve inches deep.
 8. If using gravel, add a 3-4 inch layer of sand on top of the gravel. This will aid in drainage.
 9. Loosely pile the soil back in or replace the soil with rain garden soil mix: 50 - 60% sand, 20 - 30% topsoil, and 20 - 30% compost.
 10. The height of the finished garden bed should be lower than the height of the soil surrounding the bed, approximately 5-7 inches lower. You can bow the sides slightly to aid in the look of the garden, but garden should not be level with the surrounding soil.
 11. Redirect downspouts to flow into designated area by constructing berms or swales, or use pipes:
 - To create berms along the downhill side of the rain garden:
 - a. Pile up an appropriate amount of soil using left over soil from the rain garden hole. Usually five inches tall is enough to retain water but not drown plants.
 - b. Compact the soil by walking on it and tamping it down well.
 - c. To help minimize erosion of the berms, either put a two inch layer of mulch on the berm or plant drought resistant plants for ground cover. Yellow sedum is a good choice for a ground cover and a native variety can be found.
 - To create a swale from the downspout to the rain garden:
 - a. The swale can be as wide or narrow as you want it, and does not need to be very deep.
 - b. The slope of the swale should be not more than 3:1, horizontal to vertical.
 - c. Remove the sod and dig a trench with the dimensions you wish your swale to be.
 - d. Once you have finished your trench, either replace the sod or reseed the swale. You will need to water the sod or seeds well until they are established.
 - e. Attach a universal downspout adapter to the downspout and redirect it into the swale.
 12. Grade the area so that water entering the garden will spread out over the whole area.
 13. Plant selected plants (see list of suggested plants on p.35).
 14. Fertilize plants according to the package directions.
 15. Put a three to four inch layer of mulch down to help retain moisture and deter weeds.
 16. Water young plants until well established.
-

Suggested Rain Garden Plant List

Native plants are the best choice for an interior rain garden as they require less maintenance and are tolerant of our varied conditions. Be sure to check the latin name if you wish to use plants that are native to Alaska and avoid planting invasive species.

Plant Type	Plant Name	Latin Name	Sun	Height	Bloom Color
Deciduous shrubs	*Tundra Rose	<i>Dasiphora fruticosa+</i>	Full	3-4 feet	Yellow
	*Red-Twig Dogwood	<i>Cornus sericea</i>	Part/Full	5-8 feet	White
	*Silverberry	<i>Eleagnus commutata</i>	Full	12 feet	Yellow
	*Prickly Rose	<i>Rosa acicularis</i>	Part/Full	4 feet	Pink
	*Soapberry	<i>Shepherdia canadensis</i>	Part	6 feet	Yellow/Green
	*Lingonberry	<i>Vaccinium alaskaense</i>	Part	3-5 feet	White
	*Highbush Cranberry	<i>Viburnum edule</i>	Part/Full	4-8 feet	White
Perennials	**Columbine	<i>Aquilegia formosa</i>	Shade/Part	8-14 inches	Red
	*Alaska Wild Iris	<i>Iris setosa</i>	Part/Full	12-24 inches	Purple
	*Ostrich Fern	<i>Matteuccia struthiopteris</i>	Shade/Part	30-36 inches	
	*Bluebells	<i>Mertensia paniculata</i>	Part/Full	18-30 inches	Blue/Purple
	*Chocolate Lily	<i>Fritillaria camschatcensis</i>	Part/Full	18 inches	Purple/Brown
	**Jacob's Ladder	<i>Polemonium acutiflorum</i>	Part/Full	3-6 Inches	Blue
	*Northern Monkshood	<i>Aconitum delphinifolium</i>	Part/Full	10-30 inches	Blue/White
	*Dwarf Fireweed	<i>Chamerion latifolium++</i>	Full	2 feet	Magenta/Pink
	**Indian Paintbrush	<i>Castilleja caudata</i>	Full	8-16 inches	Green/Yellow
	**Violet	<i>Viola spp</i>	Shade	4-12 inches	Purple
*Northern Geranium	<i>Geranium erianthum</i>	Part/Full	14-24 Inches	Blue/Purple	

* Indicates Native Plant Species ** Indicates There Are Native And Non-Native Varieties/Species"

Older Latin Names: + *Potentilla fruticosa* ++ *Epilobium latifolium*

Maintenance:

Weed and water frequently until the plants are established. Fertilize only when necessary to maintain good growth.

For more information about this and other Green Infrastructure Projects please visit:

www.fairbanksgig.com

Sources:

Alaska Department of Fish and Game, Native Alaskan and Exotic Plants Used by Wildlife

www.wildlife.alaska.gov/index.cfm?adfg=birds.plants

Low Impact Development Center, Inc., Bioretention Benefits

www.lid-stormwater.net/bio_benefits.htm

Low Impact Development, Rain Garden Design Templates

www.lowimpactdevelopment.org/raingarden_design/index.htm

Cuyahoga Soil and Water Conservation District, Rainwater Garden Plans

www.cuyahogawcd.org/grantfunded-raingardens.htm

Municipality of Anchorage. (n.d.). Rain Gardens: A How-To Manual for Homeowners in the Municipality of Anchorage. <http://anchorageraingardens.com/RGmanualWEB.pdf>

Rain Gardens of West Michigan, Rainwater Garden Plans

www.raingardens.org

University of Alaska Fairbanks Cooperative Extension Service, A Key to Flower Growing in Alaska

www.uaf.edu/ces/publications-db/catalog/anr/HGA-00139.pdf

Riparian Zone Revegetation

Live on a Waterway? Have Erosion Issues?

Land along waterways, called the riparian zone, has many important functions. Healthy vegetated riparian areas keep your land from eroding, improve water quality and quantity, provide important fish and wildlife habitat, and help sustain aquatic life.



photos: US Fish and Wildlife Service

“Riparian” refers to something that lives or is located next to a waterway. Native plants in riparian areas reduce erosion, improve water quality and quantity, provide wildlife habitat, and help sustain aquatic life. Roots of plants protect the stream bank and keep soil (sediment) out of the water. This keeps silt from covering the gravel on the river bed where juvenile salmon and other life forms spawn. Undercut banks with overhanging plants and large woody debris are also important habitat for fish and other aquatic wildlife.

Cold Climate Considerations:

See list on back for specific plants that will survive in a Fairbanks area riparian zone.

Special Considerations:

You may need state, federal, city, or borough permits before you restore or replant streambanks. It is a good idea to contact agencies early in your planning (one year before project in spring or summer). This will allow time to get permits, grant funds if available, and other help. It may take 30 days after applying to get a permit and much longer for some projects. For help with your project or to ask questions, call Fish and Wildlife Service Partners program at 456-0209 or the Alaska Department of Fish and Game Habitat Division at 459-7289.

Cost Estimates:

- Brush Layers - \$105/ft
- Trenched Willow - \$50/ft
- Veg Mat - \$8/ft
- Cabled Spruce - \$45/ft
- Root Wads - \$225/ft

Time Estimate:

This project could take one day to many weeks to complete depending on level of contractor involvement, type and size of project.

Pros:

- Reduces water runoff and increases groundwater infiltration.
- Reduces property erosion.
- Minimal maintenance required.
- Helps keep water bodies cool.
- Improves habitat for fish, birds and other aquatic life.
- Helps maintain aquatic habitats.

Cons:

- Permits may be necessary and can delay project.
- Should be installed during low water periods.

Materials:

- Native Plants
- Veg Mat (removed with permission)
- Coir Logs (12”diameter)
- Wooden stakes
- Biodegradable Fabric C125 BM (ENC2 eqv.)
- Biodegradable Fabric Coir Mat 700 (CF7 eqv.)
- Fill soil, topsoil if possible
- Gravel
- Galvanized or stainless steel cable (1/8 inch)
- Duckbill earth anchor (size 66) and Ferrules

Tools:

- Shovels, pickaxes, loppers
- Sledgehammer
- Pruners
- Small Earthmover (optional)
- Cable Cutter



Cabled Spruce Trees

- Cable the spruce trees along the river bank with the butt end of the tree facing upstream.
- Overlap the trees by 1/2 to 1/3 the length of the tree like shingles.
- Hold the trees in place with a duck bill anchor (size 66) driven into the river bank.
- Cable the trees, drawn tightly against the bank at and below ordinary high water.
- Do not remove limbs from the trees before installing.
- If the cabled trees are not maintained and deteriorate, remove all visible cables and anchors that remain below OHW.

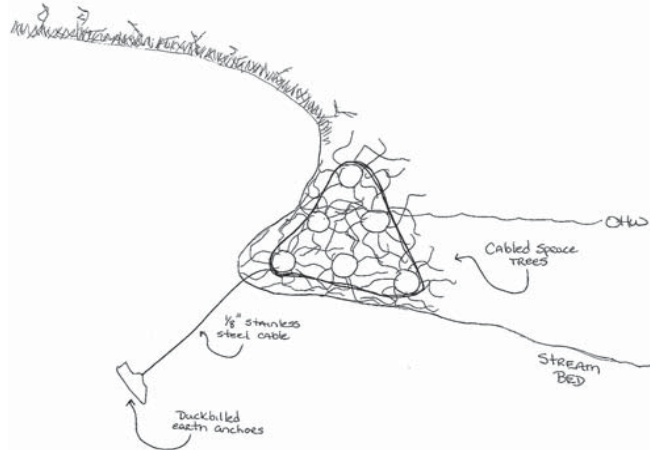

Brush / Hedge Brush Layering Step-by-Step

①

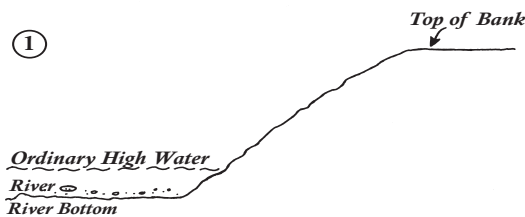

②

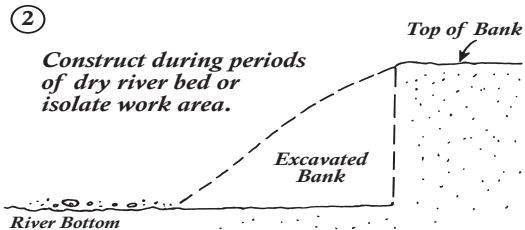

③

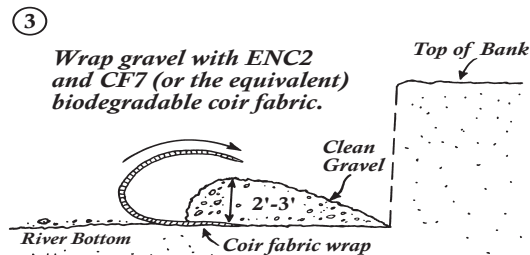

④

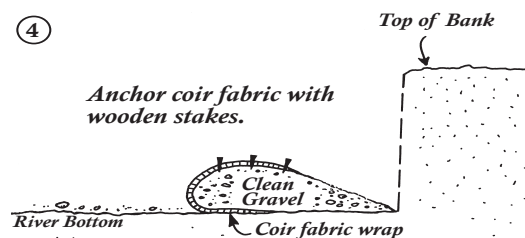

- ⑤ Crisscross layers of 15 dormant cuttings per foot or 10 rooted cuttings per foot. Deposit topsoil over cuttings and water liberally. Compress soil to 2 - 4 inches.

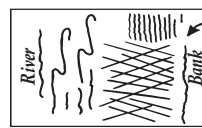

Plan View

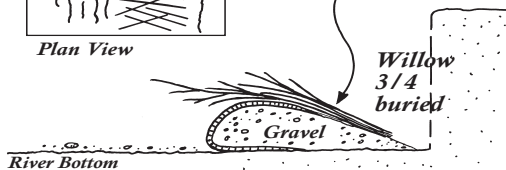

- ⑥ Wrap second layer of soil / topsoil mix with ENC2 and CF7 coir fabrics (or equivalent) 2' - 3' over topsoil and stake fabric into place. Water each layer liberally and compress soil / topsoil mix to 12" - 14" before willow placement.



- ⑦ Repeat steps 4, 5, 6 until desired bank height is reached.

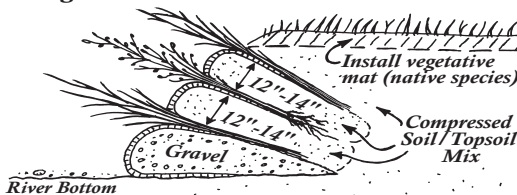

- ⑧ Trim vegetative mat shoots by 1/3 to compensate for root loss and promote root growth.

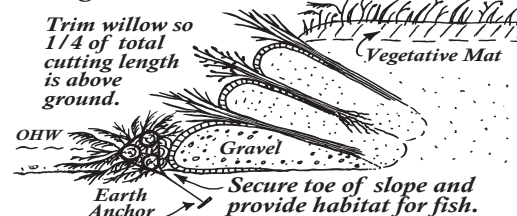

Maintenance:

- Water new plants well each day through the hot, dry part of summer.
- Remove unnecessary debris regularly.

Tree and Shrubs	Plant Common Name	Latin Name	Zone	Revegetation Uses*
Deciduous Shrubs	Feltleaf Willow	<i>Salix alaxensis</i>	3-4	DC, LS, B, BL, L, H, RC, T, S
	Red Osier Dogwood	<i>Cornus stolonifera</i>	3	DC, LS, B, BL, H, RC, T, S
	Lingonberry	<i>Vaccinium vitus-idea</i>	3	RC, T, S
	Rugosa Rose	<i>Rosa rugosa</i>	3	RC, R, T, S
	Diamond Leaf Willow	<i>Salix planifolia spp. Pulchra</i>	3-4	DC, LS, B, BL, H, RC, T, S
	Highbush Cranberry	<i>Viburnum edule</i>	3	RC, T, S
	Pacific Willow	<i>Salix lasiandra</i>	3-4	DC, LS, B, BL, L, H, RC, T, S
	Thin Leaf Alder	<i>Alnus tenuifolia</i>	4	RC, T, S
Coniferous Trees	Whites Spruce	<i>Picea glauca</i>	4-5	RC, T, S
	Larch/Tamarack	<i>Larix laricina</i>	5	RC, T, S
Deciduous Trees	Alaska Paper Birch	<i>Betula neoalaxensis</i>	5	DC, LS, B, BL, H, RC, T, S
	Balsam Poplar	<i>Populus balsamifera</i>	5	DC, LS, B, BL, H, RC, T, S
	Quaking Aspen	<i>Populus tremuloides</i>	5	H, RC, T
Grasses and Sedges	Plant Common Name	Latin Name	Zone	Availability
Grasses	Bluejoint Reedgrass	<i>Calamagrostis canadensis</i>	2-3	Limited Seed Supply, Transplants from wild
	Bering Hairgrass "Norcoast"	<i>Deschampsia caespitosa</i>	2-3	Seed Available High Demand
	Red Fescue "Arctared" "Boreal" "Pennlawn"	<i>Festuca rubra</i>	2	Seed Available
	Polargrass "Alyeska" "Kenai"	<i>Arctagrostis latifolia</i>	2	Alyeska seed available
	Sloughgrass "Egan"	<i>Beckmannia syzigachne</i>	2	Seed available
Sedges	Water Sedge	<i>Caryx aquatilis</i>	1-2	Contract seed collections
	Lyngby Sedge	<i>Caryx lyngbyaei</i>	1-2	Contract seed collections

*Key to Revegetation Uses:

DC : dormant cutting B: bundles L: live siltation RC: rooted cutting R: root cutting
 LS: Live Stakes BL: brush layer H: hedge layering T: transplants S: seed

Riparian Zones

For more information about this and other Green Infrastructure Projects please visit: www.fairbanksgig.com

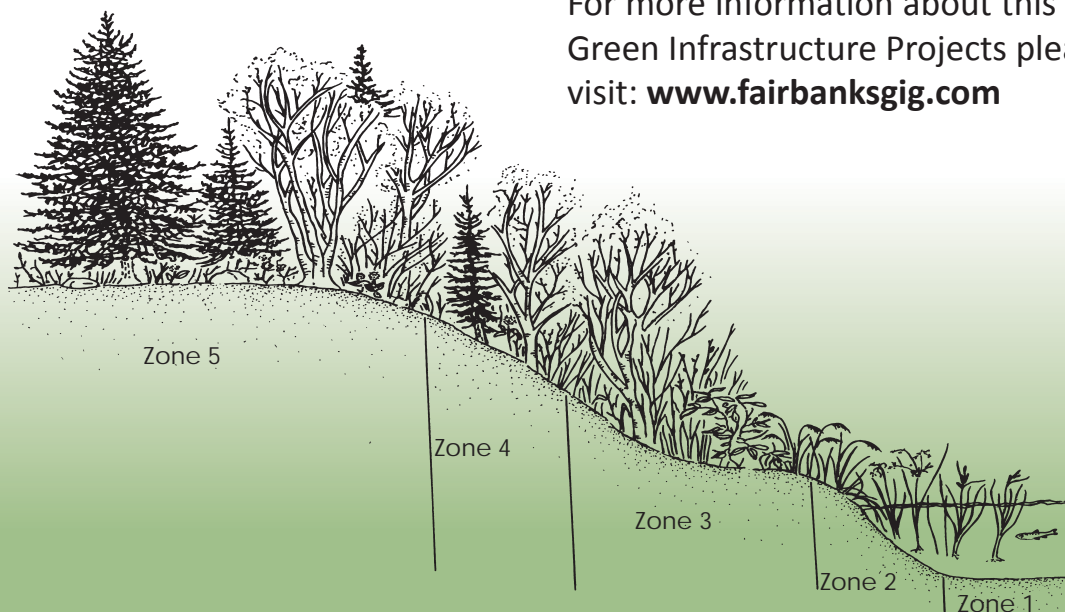

Stormwater Trees

Trees are Umbrellas

Trees are one of the most effective and least expensive way to reduce and filter stormwater runoff. Trees intercept and store rain and snow on leaves, branches and trunk bark. Trees also remove pollutants from the air and add seasonal interest to your yard and neighborhood.

Planting trees is a beautiful way to help keep our rivers and streams clean and healthy.



Trees are Umbrellas

Have you ever stood under a large tree during a downpour and noticed how dry it is? The leaves, branches, and trunk bark intercept and hold large amounts of water. The water then is evaporated into the air or it drips and flows slowly down to the ground.

Forests are Sponges and Trees are Pumps

On the ground under trees, fallen leaves and mulch form a spongy layer that helps retain soil moisture and allows rain to percolate into the soil rather than running off carrying with it oil, metal particles and other pollutants. Below ground, roots hold the soil in place and absorb water that will eventually be released into the atmosphere as the tree transpires. A large tree in full leaf may lift a ton of water from the soil and carry it to the leaves and back into the air on a warm day.

Cold Climate Considerations:

See sources on the back page of this guide for recommended tree species for Fairbanks and your site.

Materials:

- Wood chips for mulch
- Water
- Stakes and ties, only if needed to stabilize tree: 6-foot 2"x2" wooden stakes with one pointy end; tree tie webbing that is at least ¾" wide.

Tools:

- Shovel and/or hoe
- Spade (flat) to remove turf grass

Steps:

1. Select the right place for your tree

Consider soil conditions, exposure to sun and wind, drainage, hardiness zone, space constraints, and activities that take place in the area. Most roots grow in the top 4 to 18 inches of soil and far beyond the canopy. Allow space for your tree to reach full size both above and below ground without interfering with vehicles and pedestrians or structures.

Large trees will retain and filter more rain and snow than small trees. Select tree species with features that intercept more water such as large leaves and rough bark. Evergreen trees intercept rain and snow year round. Plant trees in small groves where possible and improve the care of existing trees so they will have long lives.

2. Avoid sites where your tree will cause problems or be damaged.

- Don't plant where snow is stored or slides from roofs.
- Don't block traffic signs and sight lines at intersections and driveways.
- Don't plant too close to buildings or chimneys; trees may drop debris on roofs or become fire hazards.
- Don't create shade where you want sunlight and don't block desirable views.
- Don't plant trees too close together; they won't achieve their mature size and shape,

3. Avoid Utility Lines

Plant trees and shrubs where, at maturity, they will not interfere with, or block access to, overhead or underground utility lines, poles or transformer boxes. Leave an 8-foot-wide corridor directly under lines free of trees or shrubs to allow access for utility equipment and workers.

Alaska Dig Line
811 or 479-3118

Call for utility location before you dig.

4. Select a Good Quality Tree

A healthy high quality tree will be an asset that increases in value as it ages while a poor quality tree will require more maintenance and may become a liability.

A High Quality Tree:

- Is free of wounds and incorrect pruning cuts – no stubs or flush cuts.
- Branches are evenly spaced and form wide angles with the trunk (45-90 degrees).
- Trunk stands upright without the support of stakes.
- Roots fill container but are not circling the root ball. Roots are healthy and white with no sign of decay.
- Has no weeds in root ball or container.



A Poor Quality Tree:

- Roots are pot-bound or circling trunk or inside of container.
- Angles between branches and trunk are narrow; as tree grows it may crack and split apart.
- Leaves are too small and yellow.
- Weeds are growing in container; they may be invasive and/or difficult to remove.
- Trunk has wounds, damage, or incorrect pruning.
- There are signs of insects or disease damage.



5. Plant It Right

- Before digging the hole, remove all twine, tags and wrap from around the trunk and cut away and remove the container, wire basket and/or burlap.
- Locate the trunk flare, which is where the first major root extends out from the trunk. Remove soil from top of root ball until main root system is exposed.
- You may buy bare root trees or soak the root ball in a large tub of water to remove soil.
- Separate and spread the roots so that they will grow out into the surrounding soil. Prune roots that are diseased, damaged or circling the container or root ball; make clean cuts back to white, healthy tissue.
- Remove turf and loosen soil in a saucer-shaped hole at least two times the spread of the roots and no deeper than height from base of trunk flare to bottom of roots. Remove large rocks. The hole should be wide and shallow with sloping sides.
- Set the tree in the hole on solid ground so that it does not settle. The trunk flare must be just above ground level. Roots of trees planted too deeply may not get enough water and oxygen as the tree grows.
- If soil is very poor or compacted you may mix a little topsoil with existing soil.
- Use water to settle the soil - add 1/3 soil, water, and repeat. Do not compact soil or damage roots by walking on wet soil.
- Stake only if needed to stabilize the tree. Use smooth, wide, flexible material for ties that support the tree but allow it to sway; trees grow stronger root systems and trunks if allowed some wiggle room. Never place wire around the trunk to stabilize it, not even in a rubber hose.

- Apply mulch 3 to 4 inches deep in a circle extending 2 to 3 feet from the trunk or to the drip line. Keep mulch 6 inches away from the trunk. Water well after mulching.
- Prune only dead and damaged branches at planting. Do not fertilize newly planted trees.

Mulch improves the soil, reduces compaction, holds moisture, moderates soil temperatures helps keep lawn mowers and weed whips away from trunks.

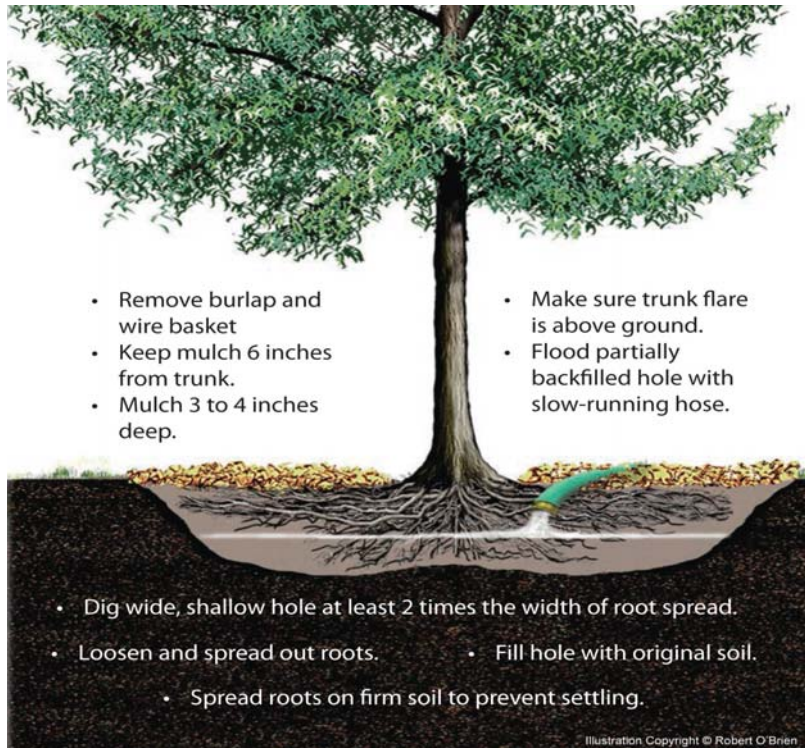

6. Maintenance

- Water trees during the first five years after planting if soil 4 inches down is dry. Water slowly until soil is moist to a depth of 12 inches.
- If tree is staked, check ties regularly to be sure the trunk is not damaged. Remove ties after one growing season or as soon as roots are well anchored.
- Most landscape trees do well with little or no fertilizer. If symptoms indicate a need, apply slow release fertilizer in early summer or late fall and follow product directions.
- If symptoms indicate a need, apply slow release fertilizer in spring, early summer or late fall and follow product directions.
- Keep lawn mowers and weed whips away from tree trunks to avoid damage.
- Improve the health of your trees by maintaining a layer of mulch 3 to 4 inches deep to the drip line and 6 inches away from the trunk. Fallen leaves may be left on the ground to serve as mulch.
- Contact a qualified professional tree service to prune large trees.

For more information about this and other Green Infrastructure Projects please visit:

www.fairbanksgig.com

Sources:

- For the right tree or shrub species for your location, see the Landscape Plants of Alaska website, - <http://www.alaskaplants.org/>
- Plant a Tree: an Alaskan guide to tree selection, planting and care, and publications on tree pruning and maintenance. <http://forestry.alaska.gov/community/publications.htm>
- Trees and Shrubs for Interior Alaska Landscapes by Patricia S. Holloway, UAF Georgeson Botanical Garden.
- USDA Forest Service Pacific SW Research Station publications on Urban Ecosystems and Processes. Is all your Rain Going Down the Drain and How Trees Can Retain Stormwater Runoff. - <http://www.fs.fed.us/psw/programs/uesd/uep/research/water.shtml>

Swales and Berms

Swale



Want to water less?

A vegetated swale is a grass-lined depression that slows down runoff water and lets the water soak into the soil.

Berms are low earthen walls next to ditches that can help retain runoff along the downhill side.

Berm



Berms and swales are used to conserve soil and water. Vegetated swales and berms can direct water to where you wish it to drain; this may be a rain garden or a dry well or any other area where excess water can be filtered before it reaches a waterway. Swales can be dug by hand and cost next to nothing to construct.

Cold Climate Considerations:

See “Steps to create a berm” for examples of plants that will survive on a Fairbanks berm.

Cost Estimate:

- Self installed
\$3 - \$7 per sq ft
- Professionally installed
\$10 - \$15 per sq ft

Time Estimate:

- This project will take one to three days to complete.

Pros:

- Aesthetically pleasing.
- Reduces water runoff.
- Increases groundwater infiltration.
- Increases property value.
- Creates habitat for birds and butterflies.

Cons:

- Surface freezing in the fall reduces the water retention potential during that season.
- A restricted list of suitable plants.

Materials:

- Appropriate plants
- Extra soil if needed
- Non-toxic paint, stakes or string
- Native plant seeds or grass seeds

Tools:

- Shovel
- Spade
- Measuring tape

Steps to create a vegetated swale:

Steps to create a vegetated swale:

1. Choose the right location for your swale:
 - a. Note the direction of runoff and low spots where water collects.
 - b. Swales can be used to convey roof runoff to rain gardens, dry wells, or other areas of your lawn. Swales should not be used to direct runoff into the street or onto other nonporous surfaces.
 - c. Make sure that the chosen location runs downhill and ends at least ten feet away from buildings with basements.
 - d. Do not locate on or near septic tanks or wellheads.
 - e. Before you dig, be aware of underground service lines or utilities. Call 1-800-478-3121 or go online at www.akonecall.com to have the underground lines marked.
2. Once you have chosen a location, define the borders using non-toxic paint, stakes and string, etc.
 - a. The swale can be as wide or narrow as you want it.
 - b. The depth of the swale can be as deep as you like. For residential purposes six inches or less is adequate.
 - c. The slope of the swale should be not more than 3:1, horizontal to vertical.
3. Remove the sod and dig a trench with the dimensions you wish your swale to be.
4. Once you have finished your trench, either replace the sod or reseed the swale. You will need to water the sod or seeds well until they are established.
5. Attach a universal downspout adapter to the downspout and redirect it into the swale.

Vegetated Swale

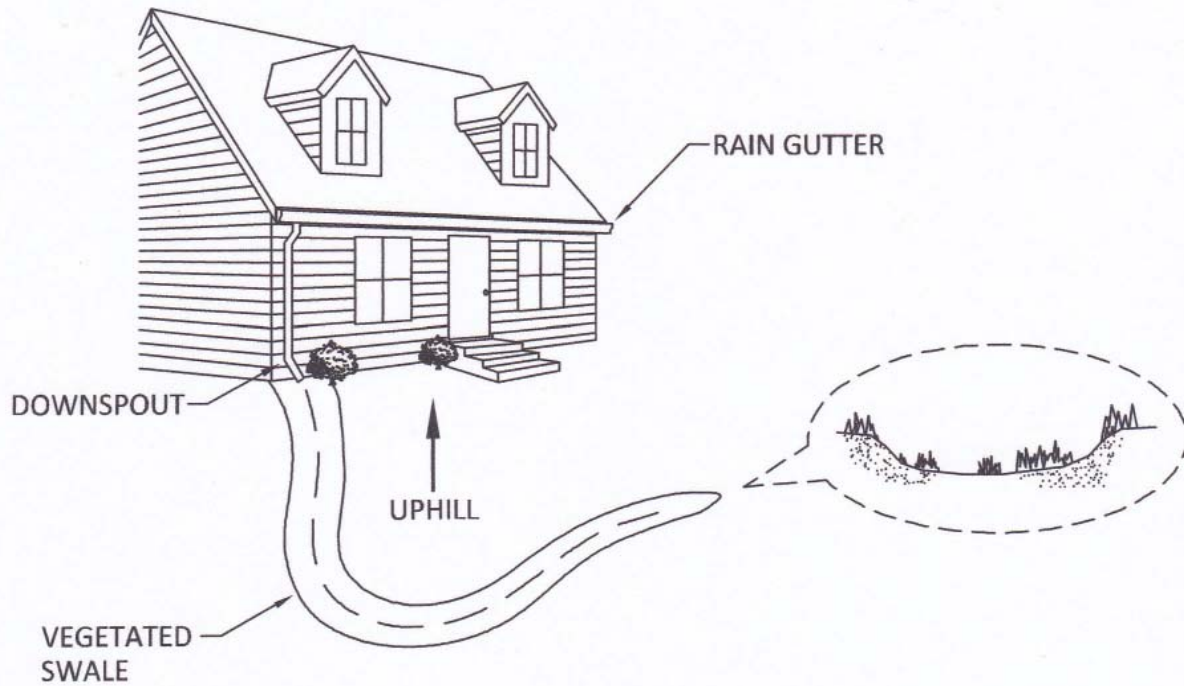

Vegetated Berm

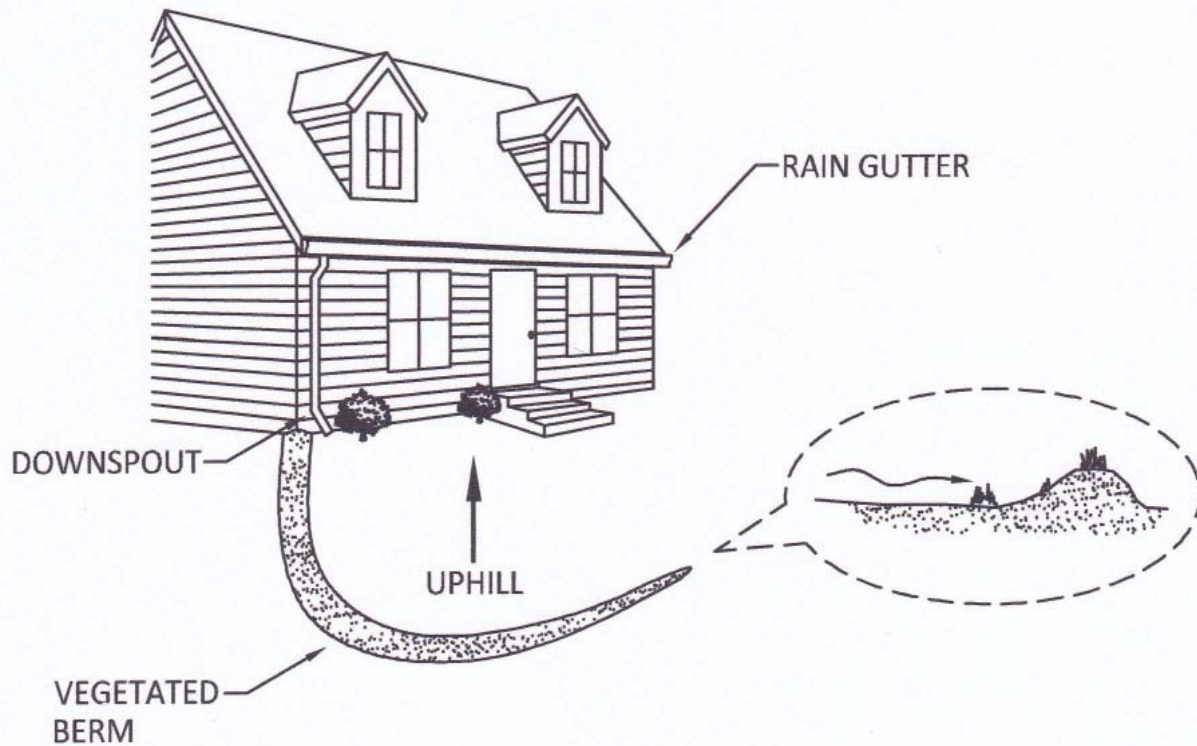

Steps to create a berm:

1. Pile up an appropriate amount of soil. Usually five inches tall is sufficient to retain water but not drown plants.
2. Compact the soil by walking on it and tamping it down well.
3. To help minimize erosion of the berms, either put a two-inch layer of mulch on the berm or plant drought resistant plants for ground cover. Rock Cress (*Arabis arendsii*), Gold Creeping Jenny (*Lysimachia mummularia* 'Aurea'), and Field Pussytoes (*Antennaria neglecta* 'Greene') are some good choices.

Maintenance:

- Weeding
- Fertilizing
- Watering, frequently until the vegetation is established, then occasionally.

For more information about this and other Green Infrastructure Projects please visit:
www.fairbanksgig.com

Sources:

Alaska Department of Fish and Game, Native Alaskan and Exotic Plants Used by Wildlife
www.wildlife.alaska.gov/index.cfm?adfg=birds.plants

Tree People website, Build Berms

www.treepeople.org/build-berms

United States Environmental Protection Agency website, National Pollutant Discharge Elimination System, Grassed Swales

http://cfpub.epa.gov/npdes/stormwater/menuofbmps/index.cfm?action=factsheet_results&view=specific&bmp=75

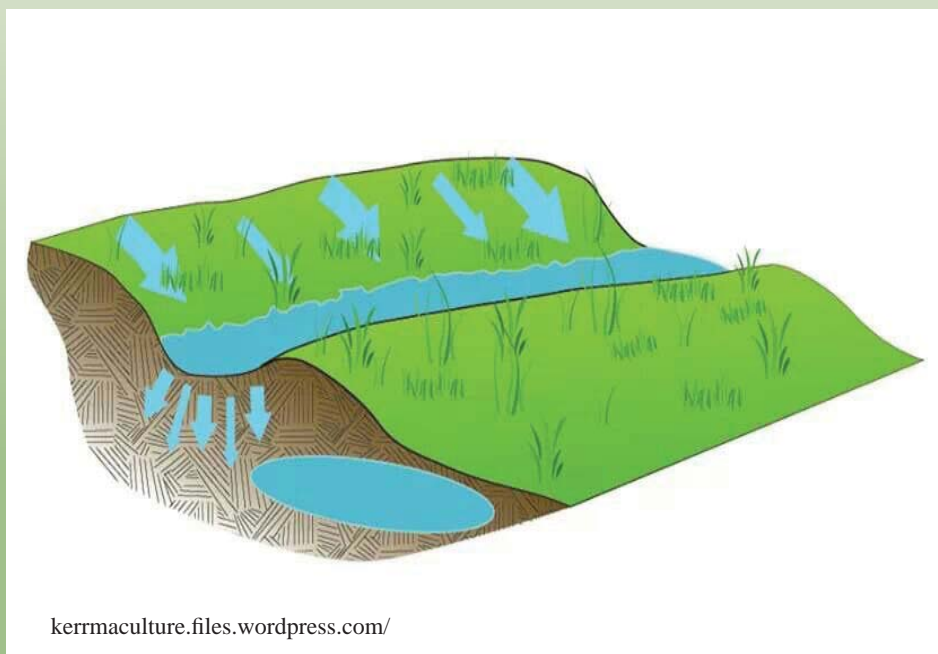

Bibliography

- Caraco, D. & Claytor, R. (December 1997). Stormwater BMP Design Supplement for Cold Climates. Ellicott City, MD: Center for Watershed Protection.
- Collins, J., Kosco, J., Scheibner, R., Schueler, T., & Swanson, J. (June 2009). Alaska Storm Water Guide. Retrieved April 2, 2010 from the Alaska Department of Environmental Conservation Division of Water website: <http://www.dec.state.ak.us/water/wnpspc/stormwater/docs/AKSWGGuide.pdf>
- Collins, K., Hirschman, D., & Schueler, T. (April 18, 2008). Technical Memorandum: The Runoff Reduction Method. Retrieved April 2, 2010 from the Virginia Department of Conservation and Recreation website: <http://www.dcr.virginia.gov/documents/stmrunredmethmemo.pdf>
- Fairbanks North Star Borough Department of Public Works. (March 2010). Storm Water BMP Design Guide. Retrieved April 2, 2010 from the Fairbanks North Star Borough Fairbanks Urbanized Area Storm Water Management Program website: http://www.co.fairbanks.ak.us/pworks/stormwatermanagementprogram/BMP_Design_Guide_Final.pdf
- Shannon & Wilson, Inc. (February 2006). BMP Effectiveness Report 18-9001-15 Fairbanks, Alaska. Retrieved April 2, 2010 from the Fairbanks North Star Borough website: <http://co.fairbanks.ak.us/PWorks/StormWaterManagementProgram/BMPEffectivenessReport.pdf>
- United States Geological Survey. (1998). Geologic Map of Central (Interior) Alaska Northeastern Region [Map]. Retrieved September 29, 2010 from <http://pubs.usgs.gov/of/1998/of98-133-a/>
- United States Geological Survey. (n.d.). Ground-Water Studies in Fairbanks, Alaska—A Better Understanding of Some of the United States' Highest Natural Arsenic Concentrations. Retrieved September 29, 2010 from <http://pubs.usgs.gov/fs/fs-0111-01/fs-0111-01.pdf>
- USKH Inc. Water Resources Group. (December 2008). Low Impact Development Design Guidance Manual. Retrieved April 2, 2010 from the Municipality of Anchorage Watershed Management Services website: http://www.muni.org/Departments/project_management/Publications/LID_Design_Guidance_1208.pdf



**Fairbanks
Green
Infrastructure
Group**

www.fairbanksgig.com

